















MITSUBISHI SEWING MACHINE PARTS CATALOG

Model..... DB189-10F. DB189-10M
DB189-11F. DB189-11M
DB189-12M. DB189-13M +IL
DB-189.

INDEX

1. 本体部  Arm Bed  F40-1
2. 針棒, 天ビン部  Needle bar and take-up lever Mechanism  F40-5
3. 上軸部分 Upper shaft Mechanism  F40-7
4. 縦軸部分  Vertical shaft Mechanism  F40-9
5. 縫目加減機構部分 Stitch regulator Mechanism  F40-11
6. 下軸部分 Rotating hook shaft Mechanism  F40-13
7. カマ機構部分 Hook Mechanism  F40-15
8. 押工機構部分 Presser foot Mechanism  F40-17
9. ソレノイド機構部分 Solenoid Mechanism  F40-21
10. メス機構部分 Knife Mechanism  F40-23
11. カム軸部分 Cam Shaft Mechanism  F40-25
12. 給油機構部分 Oil lubrication Mechanism  F40-27
13. 付属品箱 Accessories box F40-31
14. 付属品 Accessories F40-33

DB-189-10WB形 機構図

MODEL: DB-189-10WB

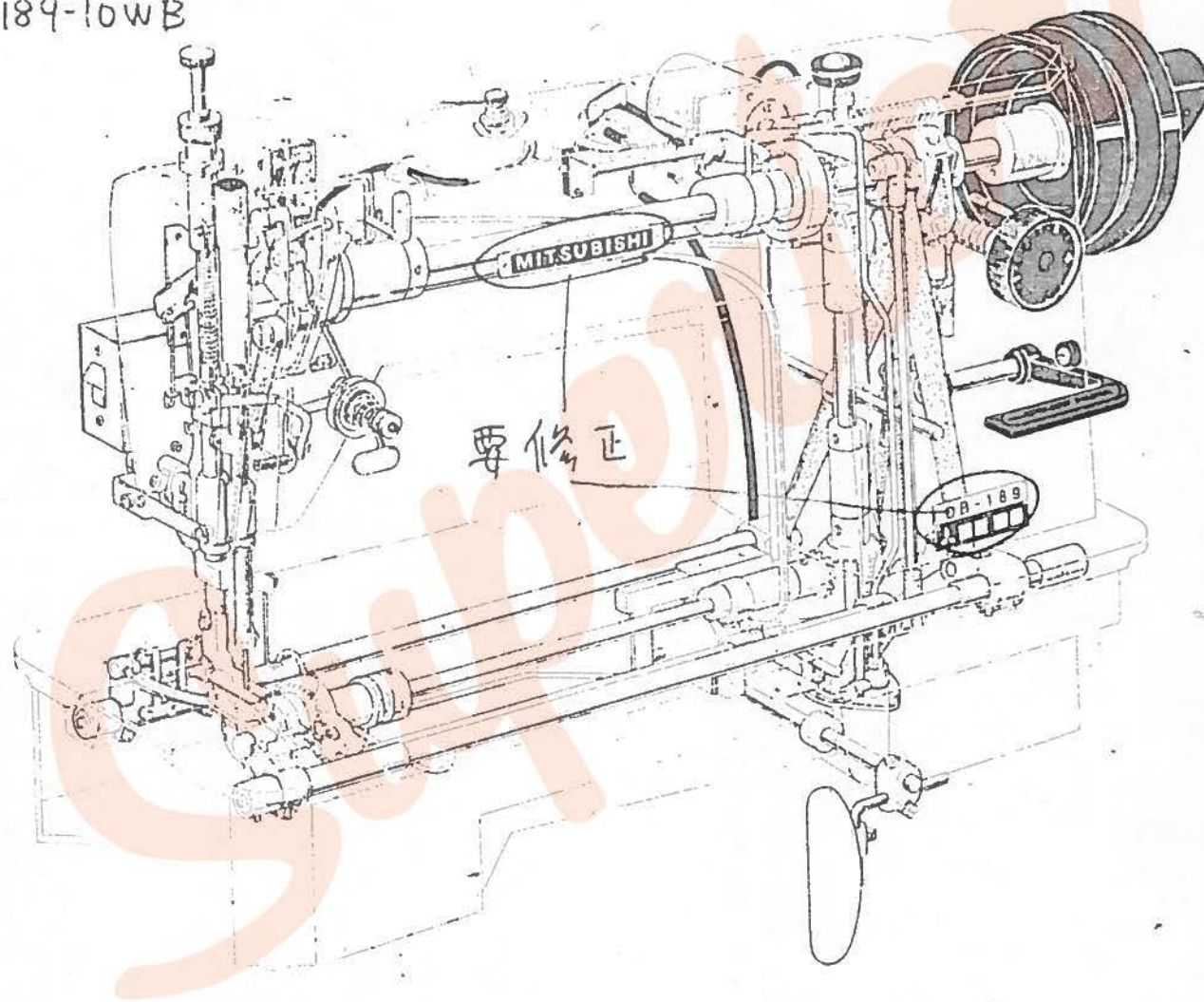

DB189形 本体部分 ARM BED

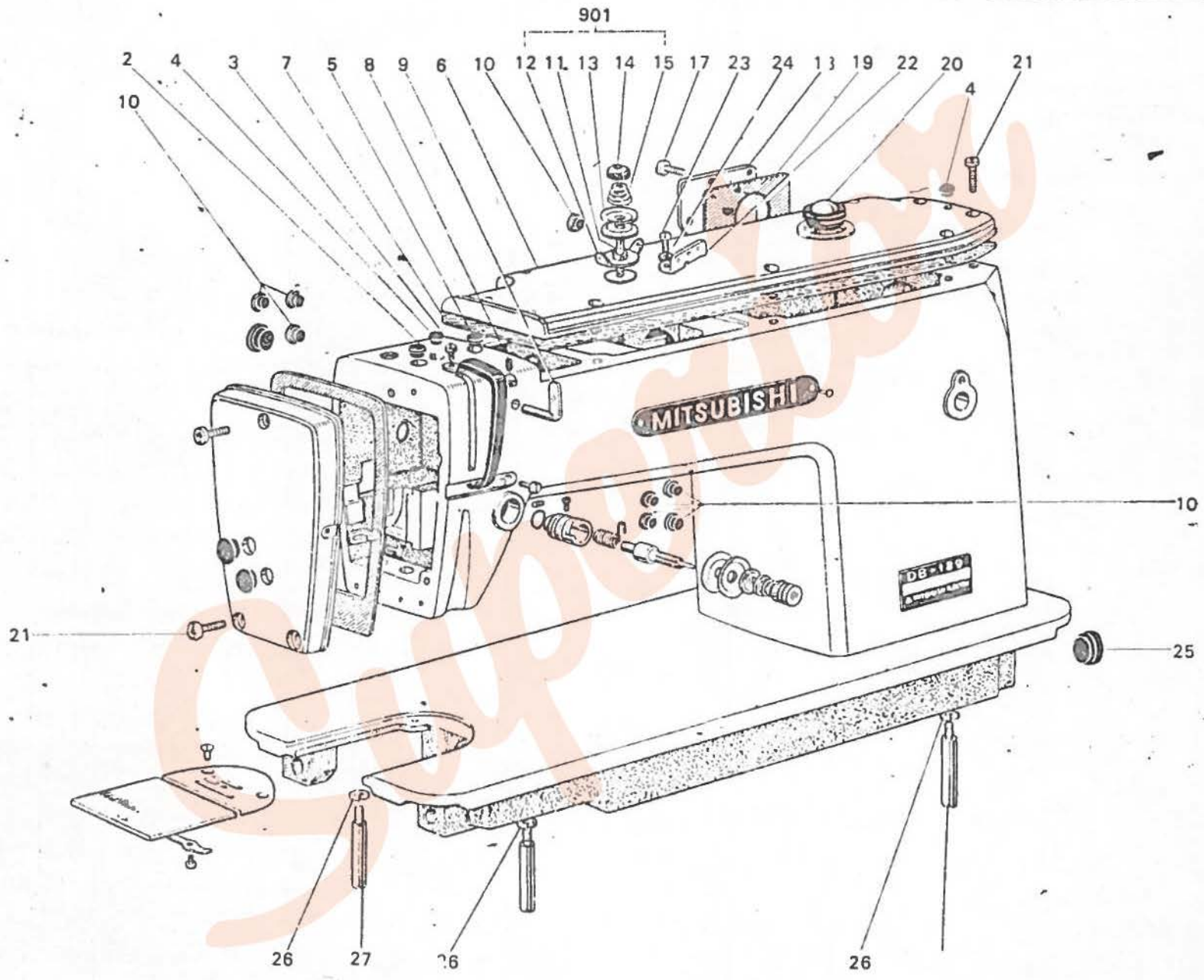

<DB189形> 本体部品 ARM BED

Fig. No.	サービス部品コード Part No.	資材コード Code No.	部品名	Name of Part	個/台 Amt. req							備考 Remarks	
					DB189-10-F40A	DB189-10-F40A	DB189-11-F41D	DB189-11-F41D	DB189-12-F42B	DB189-13-F43C	DB179-F35A		
2	MF 10A0 584	W468299H01	①ピンカバー	Thread take-up cover	①	①	①	①	①	①	①		
3	MF 1107 002	W500092H01	②ネジ 11/64(40)×5.5	Screw for Fig.2	②	②	②	②	②	②	②		
4	M9 0570 080	W502078H01	ゴム ⑤ 5.7φ赤	Rubber plug	②	②	②	②	②	②	②		
5	M9 0881 080	W502944H01	ゴム セン	Rubber plug	①	①	①	①	①	①	①		
6	MF 40A0 600	W225185H01	トップカバー	Top cover	①	①	①	①	①	①	①		
7	MF 40A0 691	W225186H01	ガスケット	Gasket	①	①	①	①	①	①	①		
8	M9 1108 001	B 503846H01	トメネジ 11/64(40)×5.5	Set screw for Fig.9	③	③	③	③	③	③	③		
9	MF 40A0 180	W475415H01	イトアンナイ	Thread guide	①	①	①	①	①	①	①		
10	M9 0880 080	W501320H01	ゴム セン 8 φ	Rubber plug	①	①	①	①	①	①	①		
901	MF 40E0 550		チョウセツキ(組)	Pre-tension Assy.	①	①	①	①	①	①	①		
11	MF 10A1 553	W502171H01	チョウシボウ	Tension stud for pre-tension	①	①	①	①	①	①	①		Fig.No.901ニ含ム
12	MF 40A0 181	W470269H01	イトアンナイ	Teread guide h	①	①	①	①	①	①	①		"
13	MF 10A1 555	W501636H01	チョウシザラ	Tension disc	②	②	②	②	②	②	②		"
14	M9 1101 046	W501637H01	ツマミナット 11/64(40)×6	Tension nut for pre-tension	①	①	①	①	①	①	①		"
15	MF 10A1 245	W502193H01	エンスイバネ	Tension spring	①	①	①	①	①	①	①		"
17	M9 1101 004	W466810H01	ブラマイネジ 11/64(40)×8	Screw for Fig. 18	④	④	④	④	④	④	④		
18	MF 40A0 742	W476418H01	フタ	Arm side cover	④	④	④	④	④	④	④		元W473512H01
19	MF 40A1 691	W476419H01	ガスケット	Gasket for Fig. 18	①	①	①	①	①	①	①		元W473513H01
20	MF 20A0 135	W472715H01	アブラマド	Oil check window	①	①	①	①	①	①	①		
21	M9 1102 004	W467880H01	ブラマイネジ 11/64(40)×10	Screw for Fig. 6	①	③	③	③	③	③	③		
22	MF 36A1 180	W471432H01	イトアンナイ	Three holes thread guide	⑤	①	①	①	①	①	①		
23	M9 1118 002	W501400H01	ヒラネジ 11/64(40)×8	Screw for Fig. 22	①	①	①	①	①	①	①		
24	M9 0502 053	W500301H01	バネザガネ	Spring washer	①	③	③	③	③	③	③		
25	M9 5003 080	W473511H01	セン	Rubber plug	④	①	①	①	①	①	①		
26	M9 0301 053	S 561111H02	バネザガネ 6	Spring washer for Fig. 27	①	④	④	④	④	④	④		
27	MF 10A0 151	W452343H01	ササエ (脚・短)	Short leg	④	②	②	②	②	②	②		

〈DB189形〉 本体部分 ARM BED

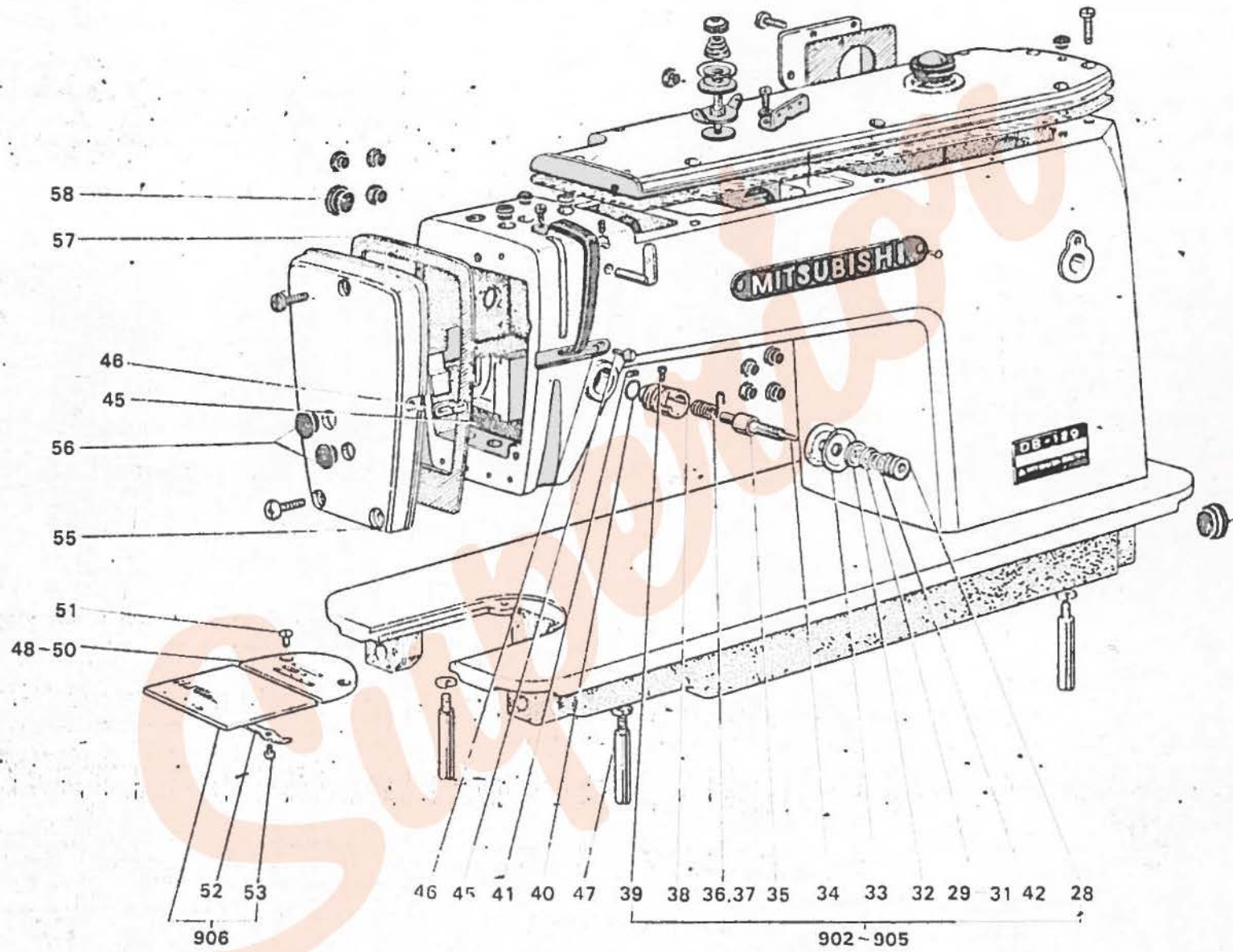

<DB189形> 本体部分 ARM BED

Fig. No.	サービス部品コード Part No.	資材コード Code No.	部 品 名	Name of Part	個 / 台 Aml. req.							備 考 Remarks
					DB189-10 Pack	DB189-10 Packer	DB189-11 Base	DB189-12 F449	DB189-13 A999	DB179-482		
902	MF 10E0 210	W450067G02	チョウセツキ(組)	Thread tension regulator Assy.	①	①	①	①			○	
904	MF 42E0 210	W335284G02	チョウセツキ(組)	Thread tension regulator Assy.					①			
905	MF 43E0 210		チョウセツキ(組)	Thread tension regulator Assy.						①		
28	M9 1603 048	W476079H01	ツマミナット 1/40(40)×4.5	Thread tension regulating thumb nut	①	①	①	①	①		○	上糸調節器組ニ含ま 元W502940H01
29	MF 10A0 245	W450781H01	エンスイバネ	Thread tension spring					①		○	
30	MF 41D0 245	W461780H01	エンスイバネ	Thread tension spring	①	①	①	①				
31	MF 43C0 245	W461786H01	エンスイバネ	Thread tension spring						①		
32	MF 10A0 556	W477611H01	チョウシザラオサエ	Thread tension releasing disc	①	①	①	①	①	①	○	元B419179H01
33	MF 10A0 555	W444059H01	チョウシザラ	Tension discs	②	②	②	②	②	②	○	
34	M9 0204 060	B 509216H01	ピン 2φ×28.4	Thread tension releasing pin	①	①	①	①	①	①	○	
35	MF 10A0 553	B 419178H01	チョウシボウ	Thread tension stud	①	①	①	①	①	①	○	
36	MF 20A0 187	W475488H01	イトトリバネ	Thread take-up spring	①	①	①	①			○	元W450070H01
37	MF 12B0 187	W461748H01	イトトリバネ	Thread take-up spring					①	①		
38	MF 10A0 709	W453140H01	ブッシュ	Thread tension regulator bushing	①	①	①	①	①	①	○	
39	M9 0901 002	W500741H01	ヒラネジ 9/64(40)×4	Set screw for Fig. 35	①	①	①	①	①	①	○	
40	MF 10A7 691	P 648001H01	Oリング	O-ring	①	①	①	①	①	①	○	元W502087H01
41	M9 1508 001	B 509088H01	トメネジ 15/64(28)×8	Set screw for Figs. 902-905	③	③	③	③	③	③	○	
42	MT 60A0 802	W476470H01	回り止め	Screw for Fig. 46	○	○	○	○	○	○	○	
45	M9 0909 003	W501901H01	マルヒラネジ 9/64(40)×6	Thread guide	③	③	③	③	③	③	○	
46	MF 10A0 181	W452151H01	イトアンナイ	Long leg	②	②	②	②	②	②	○	
47	MF 10A0 150	W461768H01	ササエ (脚・長)	Needle plate	①	①	①	①	①	①	○	
48	MF 36A1 101	W336657H01	ハリイタ	Needle plate	①	①					○	
49	MF 41D0 101	W333530H01	ハリイタ	Needle plate			①	①				
50	MF 42B0 101	W327682H01	ハリイタ	Screw for Figs. 48-50					①	①		
51	M9 1102 011	W500197H01	マルサラネジ 11/64(40)×7	Slide plate Assy.	②	②	②	②	②	②	○	
906	MF 10E0 470	W461757G01	スベリイタ (組)	Spring for Fig. 54	①	①	①	①	①	①	○	
52	MF 10A0 471	B 419207H01	イタバネ	Screw for Fig. 52	①	①	①	①	①	①	○	Fig.No.906ニ含ま
53	M9 0604 002	B 509070H01	ヒラネジ 3/32(56)×2.2	Slide plate	②	②	②	②	②	②	○	
54		B 419208H01	スベリイタ	Face plate	①	①	①	①	①	①	○	
55	MF 10A0 830	W321296H01	メンイタ	Rubber plug	①	①	①	①	①	①		
56	M9 1180 080	W502069H01	ゴムセン 11.8φ	Rubber plug	②	②	②	②	②	②	○	
57	MF 10A1 691	W450046H01	ガスケット	Gasket	①	①	①	①	①	①	○	
58	M9 1900 080	W501374H01	ゴムセン 19φ	Rubber plug	①	①	①	①	①	①	○	

〈DB189形〉 針棒,天ピン部分 NEEDLE BAR AND TAKE-UP
LEVER MECHANISM

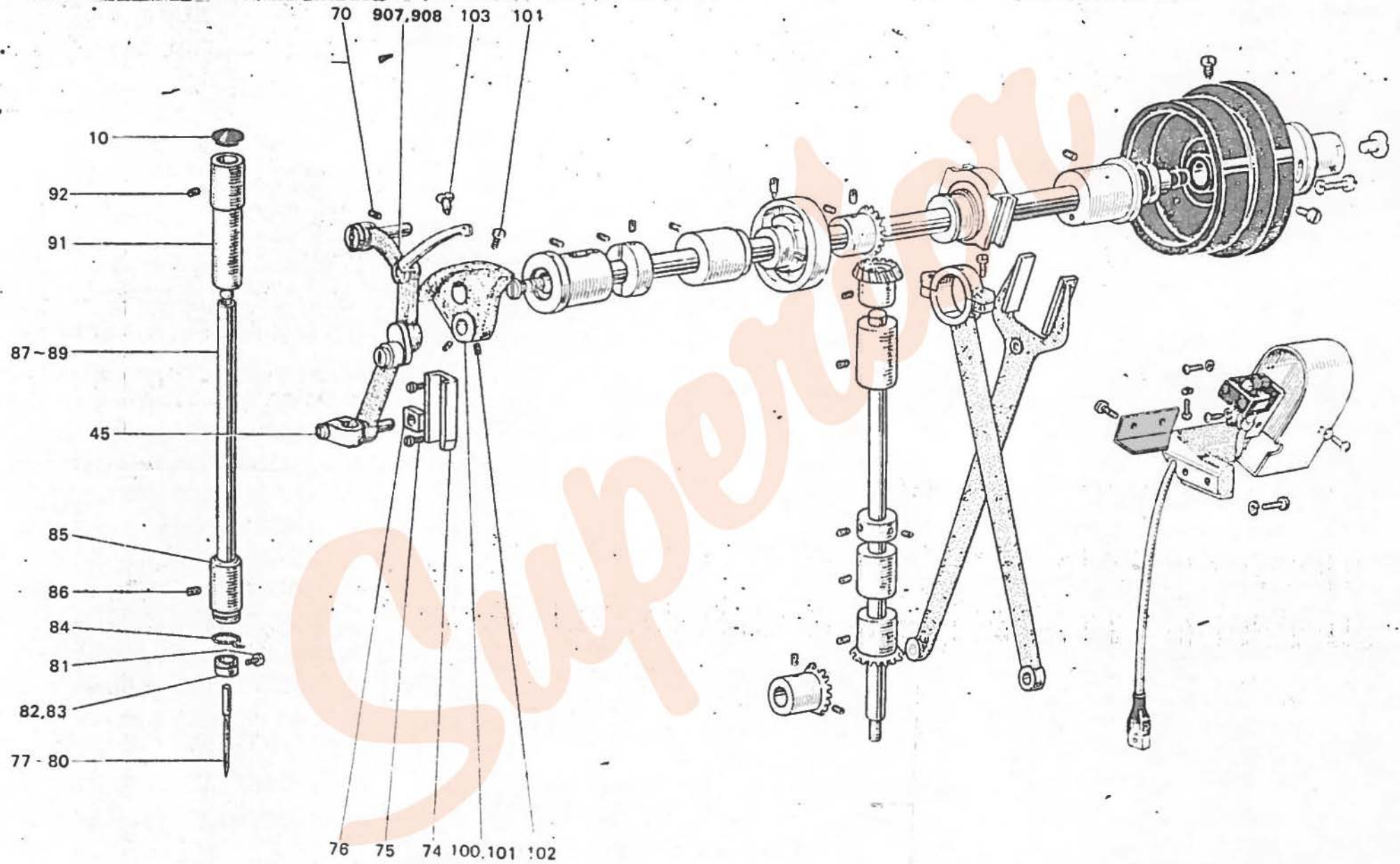

<DB189形> 針棒, 天ピン部分 NEEDLE BAR AND TAKE-UP
LEVER MECHANISM

Fig. No.	サービス部品コード Part No.	資材コード Code No.	部 品 名	Name of Part	個 / 台 Amt. req						備 考 Remarks
					DB189-10-F40A	DB189-10-F50A	DB189-11-F41D	DB189-11-F41D	DB189-12-F42B	DB189-13-F43C	
907	MF 00E0 580		テンピンレンセットカン(組)	Thread take-up lever & needle bar connecting stud Assy.	①	①	①	①		○	
908	MF 42E0 580		テンピンレンセットカン(組)	Thread take-up lever & needle bar connecting stud Assy.					①	①	
70	M9 1516 001	W500006H01	トメネジ 15/64(28)×15	Set screw for Fig. 68	④	④	④	④	④	④	○
74	MF 10A0 662	W444056H01	アンナイダイ (針棒クランクガイド)	Needle bar connecting link guide	①	①	①	①	①	①	○
75	M9 1110 002	W000294H01	ヒラネジ 11/64(40)×8	Screw for Fig. 74	①	①	①	①	①	①	○
76		W443934H01	カクヨマ	Square blkck for Fig. 65	①	①	①	①	①	①	○
77		S 970002H01	ミシンハリ DB×1 #14	Needle DB×1 #14	①	①					○
78			ミシンハリシュミツ 04:45Nm70	Needle SCHMETS 04:45 #70			①	①			
79		S 970002H02	ミシンハリ DB×1 #21	Needle DB×1 #21					①		
80		S 970002H04	ミシンハリ DB×1 #23	Needle DB×1 #23						①	
81	M9 0802 003	W502074H01	マルヒラネジ 1/8(44)×φ 4.5	Needle clamp screw	①	①	①	①	①	①	○
82	MF 10A2 181	W502075H01	イトアンナイ	Needle bar thread guide	①	①			①	①	○
83	MF 21D0 181	W468259H01	イトアンナイ	Needle bar thread guide			①	①			
84	MF 10A1 181	W502073H01	イトアンナイ	Thread guide	①	①	①	①	①	①	○
85	MF 10A0 664	W450055H01	メタル (針棒下)	Needle bar bushing (lower)	①	①	②	①	①	①	
86	M9 1102 001	W500489H01	トメネジ 11/64(40)×2.7	Set screw for Fig. 85	②	②	②	②	②	②	○
87	MF 40A0 660	W474835H01	ハリボウ	Needle bar	①	①	①				
88	MF 41D0 660	W475436H01	ハリボウ	Needle bar				①			
89	MF 42B0 660	W475437H01	ハリボウ	Needle bar			①	①	①		
91	MF 10A0 663	W450052H01	メタル (針棒上)	Needle bar bushing (upper)	①	①	⑥	①	①	①	
92	M9 1503 001	B 508971H01	トメネジ 15/64(28)×4.5	Set screw for Fig. 91	⑥	⑥	⑥	⑥	⑥	⑥	○
100	MF 20A0 383	W471445H01	クランク	Crank	①	①	①		①	①	
101	MF 21D0 383	W472544H01	クランク	Crank			②	①			
102	M9 1606 001	B 504016H01	トメネジ 1/4(40)×7	Set screw for Figs. 100-101	②	②	①	②	②	②	○
103	M9 1802 006	B 503851H01	ヒラネジボウサキ 9/32(28)×14	Set screw for Figs. 100-101	①	①	①	①	①	①	○
104	M9 1801 002	W500306H01	ヒラネジ 9/32(28)×13	Set screw for Figs. 100-101	①	①	①	①	①	①	

<DB189形> 上軸部分 UPPER SHAFT MECHANISM

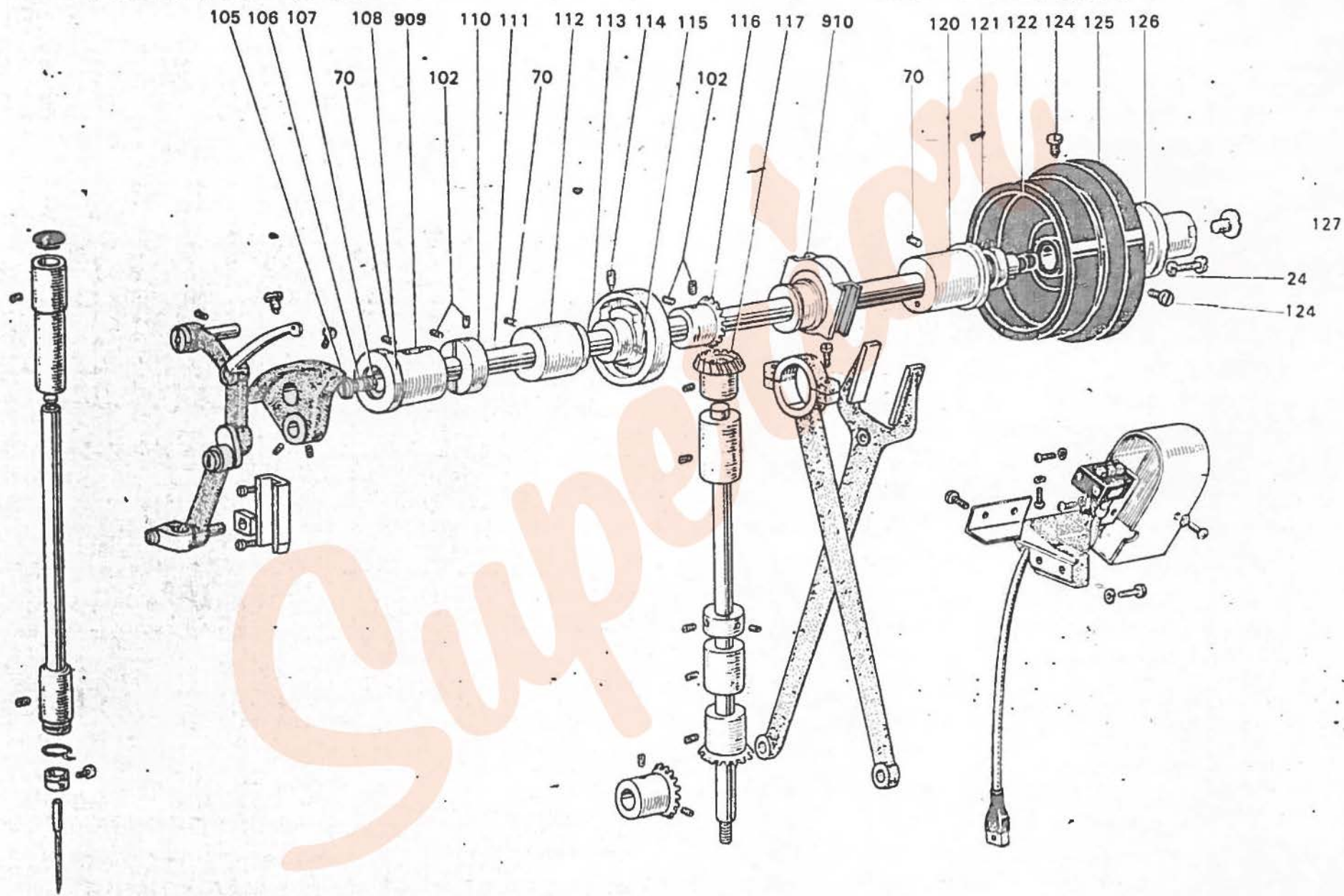

<DB189形> 縦軸部分 VERTICAL SHAFT MECHANISM

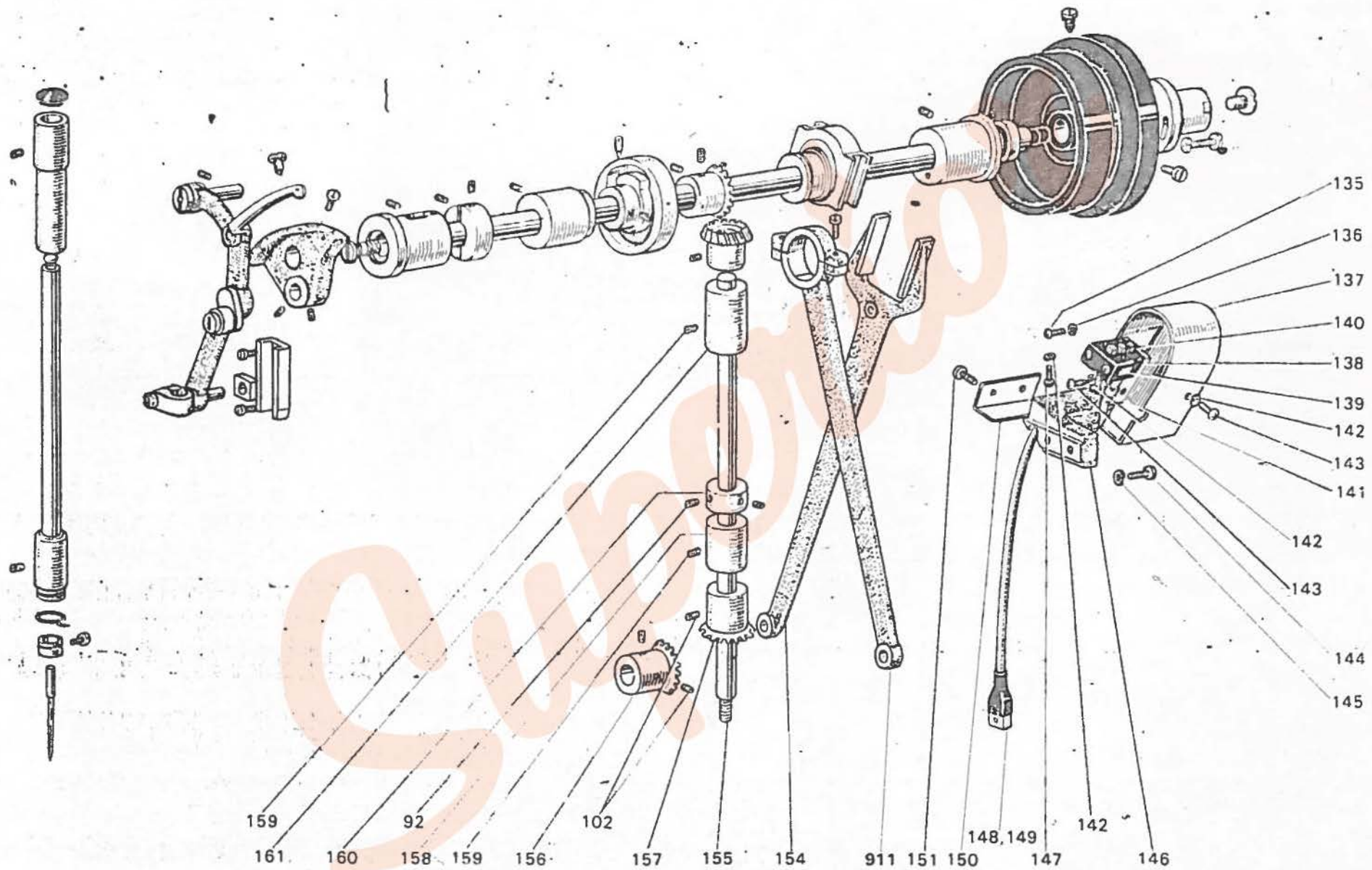

〈DB189形〉 縦軸部分 VERTICAL SHAFT MECHANISM

Fig. No.	サービス部品コード Part No.	資材コード Cqdo No	部 品 名	Name of Part	個 / 台 Amt. req							備 考 Remarks
					DB189-10-F40A	DB189-10-F40A	DB189-11-F41D	DB189-11-F41D	DB189-12-12-F42B	DB189-13-F43C	DB179-F38A	
135	M9 0424 037		P ナベネジ M4×24	Screw for Fig. 138	2	2	2	2	2	2	0	
136	M9 0401 053	S 58112H03	バネザガネ M4	Spring washer Fig. 135	2	2	2	2	2	2	0	
137	MF 40AO 339	W472583H01	カバ	Cover	1	1	1	1	1	1	0	
138	MF 40AO 752	W472581H01	ブラシホルダ	Brush holder	1	1	1	1	1	1	0	
139	MF 40AO 501	W472582H01	セツゾクメイバン	Name plate for Fig. 138	1	1	1	1	1	1	0	
140	M9 2001 099	P 439002×02	ブラシ	Brush	3	3	3	3	3	3	0	
141	M9 4004 099	S 452001H03	ナイロンクリップ HP-4N	Nylon clip for Figs. n48-149 148	1	1	1	1	1	1	0	
142	M9 0301 053	S 561121H01	バネザガネ M3	Spring washer for Fig. 143	8	8	8	8	8	8	0	
143	M9 0306 037	S 512131H01	P ナベネジ M3×6	Screw for Fig. 137	5	5	5	5	5	5	0	
144	M9 1510 002	W500676H01	ヒラネジ 15/64(28)×12	Screw for Fig. 146	2	2	2	2	2	2	0	
145	M9 0601 053	S 561121H05	バネザガネ M6	Screw washer for Fig. 144	2	2	2	2	2	2	0	
146	MF 40AO 781	W333598H01	ホルダースタイ	Holder stopper	1	1	1	1	1	1	0	
147	M9 0310 037	S 512131H02	P ナベネジ M3×10	Screw	3	3	3	3	3	3	0	
148	M9 7001 099	W473764G01	リードセン (組) L	Wire assembly	1	1	1	1	1	1	0	
149	M9 7002 099	W475460G01	リードセン (組) G	Wire assembly x	1	1	1	1	1	1	0	
150	MF 40AO 415	W472745H01	コードオサエ	Wire holder	1	1	1	1	1	1	0	
151	M9 0406 037	S 512131H37	P ナベネジ M4×6	Screw for Fig. 150	2	2	2	2	2	2	0	
911	MF 10E0 384	W320460H01	レンセツカン(組)	Crank rod Assy.	1	1	1	1	1	1	0	
154	MF 40AO 745	W335904H01	ブラマタロッド	Feed forked connection	1	1	1	1	1	1	0	
155	MF 10AO 520	W450080H01	ジク (縦軸)	Vertical shaft	1	1	1	1	1	1	0	
156	MF 10AO 332	W444111H01	カサハグルマ (下軸)	Bevel gear (hook shaft)	1	1	1	1	1	1	0	
157	MF 10AO 334	W444109H01	カサハグルマ (縦軸下)	Bevel gear (vertical shaft lower)	1	1	1	1	1	1	0	
158	MF 10AO 522	W450082H01	メタル (縦軸下)	Vertical shaft bushing (under)	1	1	6	1	1	1	0	
159	M9 1513 001	B 509060H01	トメネジ 15/64(28)×1	Set screw for Fig. 158	6	6	1	6	6	6	0	
160	MF 10AO 352	B 422844H01	カラ	Vertical shaft collar	1	1	1	1	1	1	0	
161	MF 10AO 521	W450081H01	メタル (縦軸上)	Vertical shaft bushing (upper)	1	1	1	1	1	1	0	
162		W502480H01	座金	Washer	2							
163		W478193G01	取付リング		1							
164		B 503852H01	頭ナシ止メネジ	Set screw	2							
165		W339638G01	ホルダースタイ	Holder stopper	1							
166		W500511H01	平ネジ	Screw	1							
167		W339639G01	キバン組立	Wire Assy	1							

<DB189形> 縫目加減機構部分 STITCH REGULATOR MECHANISM

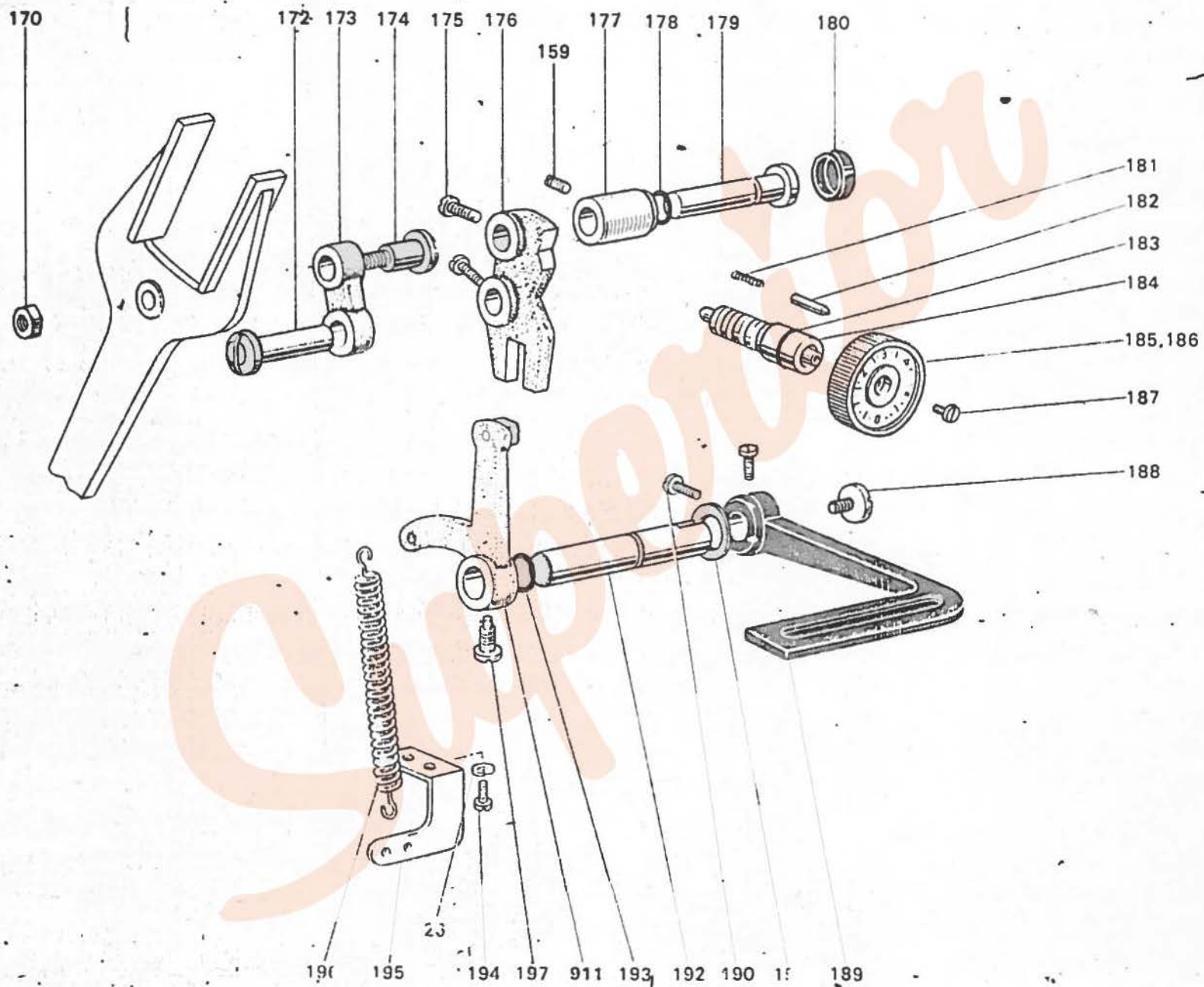

<DB189形> 縫目加減機構部分 STITCH REGULATOR MECHANISM

Fig. No.	サービス部品コード Part No.	資材コード Code No.	部 品 名	Name of Part	個 / 台 Amt. req.							備 考 Remarks	
					DB189-10-F40A	DB189-10-F40A	DB189-11-F41D	DB189-11-F41D	DB189-12-F42B	DB189-13-F42C	DB179-F30A		
170	M9 1802 045	B 508961H01	ナ ッ ト 9/32(28)	Nut for Fig. 174	①	①	①	①	①	①	①	○	
172	M9 0905 063	W501377H01	ダンツキピン 9φ×27	Set pin	①	①	①	①	①	①	①	○	
173	MF 40A0 956	W447215H01	レンセツカン	Feed connecting link	①	①	①	①	①	①	①	○	
174	M9 1807 015	W501406H01	ヒラネジダンツキ 9/32(28)×23.3	Screw for Fig. 173	①	①	①	①	①	①	①	○	
175	M9 1504 002	B 508963H01	ヒ ラ ネ ジ 15/64(28)×10	Set screw for Fig. 176	③	③	③	③	③	③	③	○	
176	MF 40A0 291	W447221H01	オクリチョウセツカム	Feed regulator	①	①	①	①	①	①	①	○	
177	MF 10A0 750	W502090H01	ブ ッ シ ュ	Feed regulator bushing	①	①	①	①	①	①	①	○	
178	M9 0500 085	S 648001H03	オ リ ン グ 1A P5	O-ring	①	①	①	①	①	①	①	○	
179	M9 0904 063	W450087H01	ダンツキジク 9φ×41	Set pin for Fig. 176	①	①	①	①	①	①	①	○	
180	M9 1980 080	W502091H01	ゴ ム セ ン 19.8φ	Rubber cap	①	①	①	①	①	①	①	○	
181	MF 10A2 572	B 509164H01	ツルマキバネ	Spring for Fig. 182	①	①	①	①	①	①	①	○	
182	MF 10A0 852	B 419163H01	モドリドメ	Stopper pin	①	①	①	①	①	①	①	○	
183	M9 1000 085	S 648001H06	オ リ ン グ 1A P10	O-ring for Fig. 184	①	①	①	①	①	①	①	○	
184	MF 40A0 297	W331474H01	オクリチョウセツネジ	Screw bar	①	①	①	①	①	①	①	○	
185	MF 10A0 631	W331475H01	ダ イ ヤ ル	Stitch length regulator dial	①	①			①	①		○	
186	MF 11D0 631	W331486H01	ダ イ ヤ ル	Stitch length regulator dial			①	①				○	
187	M9 1209 002	B 503887H01	ヒ ラ ネ ジ 3/16(28)×8	Screw for Figs. 185-186	①	①	①	①	①	①	①	○	
188	M9 1207 003	B 509288H01	マルヒラネジ 3/16(28)×6.5	Screw for Fig. 189	①	①	①	①	①	①	①	○	
189	MF 10A0 632	W453509H01	レ バ ー	Reverse sewing lever	①	①	①	①	①	①	①	○	
190	M9 1501 002	W502945H01	ヒ ラ ネ ジ 15/64(28)×8.5	Set screw for Fig. 189	③	③	③	③	③	③	③	○	
191	M9 7002 052	B 503885H01	バネザガネ	Spring washer for Fig. 189	①	①	①	①	①	①	①	○	
192	MF 40A0 454	W450088H01	シ ャ フ ト	Shaft for Fig. 189	①	①	①	①	①	①	①	○	
193	M9 0600 085	S 648001H04	オ リ ン グ 1A P6	O-ring for Fig. 192	①	①	①	①	①	①	①	○	
194	M9 1505 002	W500183H01	ヒ ラ ネ ジ 15/64(28)×13.5	Screw for Fig. 195	①	①	①	①	①	①	①	○	
195	MF 40A0 708	W476443H01	カ ケ ガ ネ	Bracket for Fig. 196	①	①	①	①	①	①	①	○	元W473521H01
196	MF 40A0 572	W447225H01	ツルマキバネ	Spring for Fig. 198	①	①	①	①	①	①	①	○	元W473520H01
911	MF 40E0 950	W462614G01	レ バ ー (組)	Reverse sewing crank Assy.	①	①	①	①	①	①	①	○	
197	M9 1501 007	B 509256H01	トメネジボウサキ 15/64(28)×14.5	Set screw for Fig. 198	①	①	①	①	①	①	①	○	Fig.No.911ニ含ム

<DBI 89形> 下軸部分 ROTATING HOOK SHAFT MECHANISM

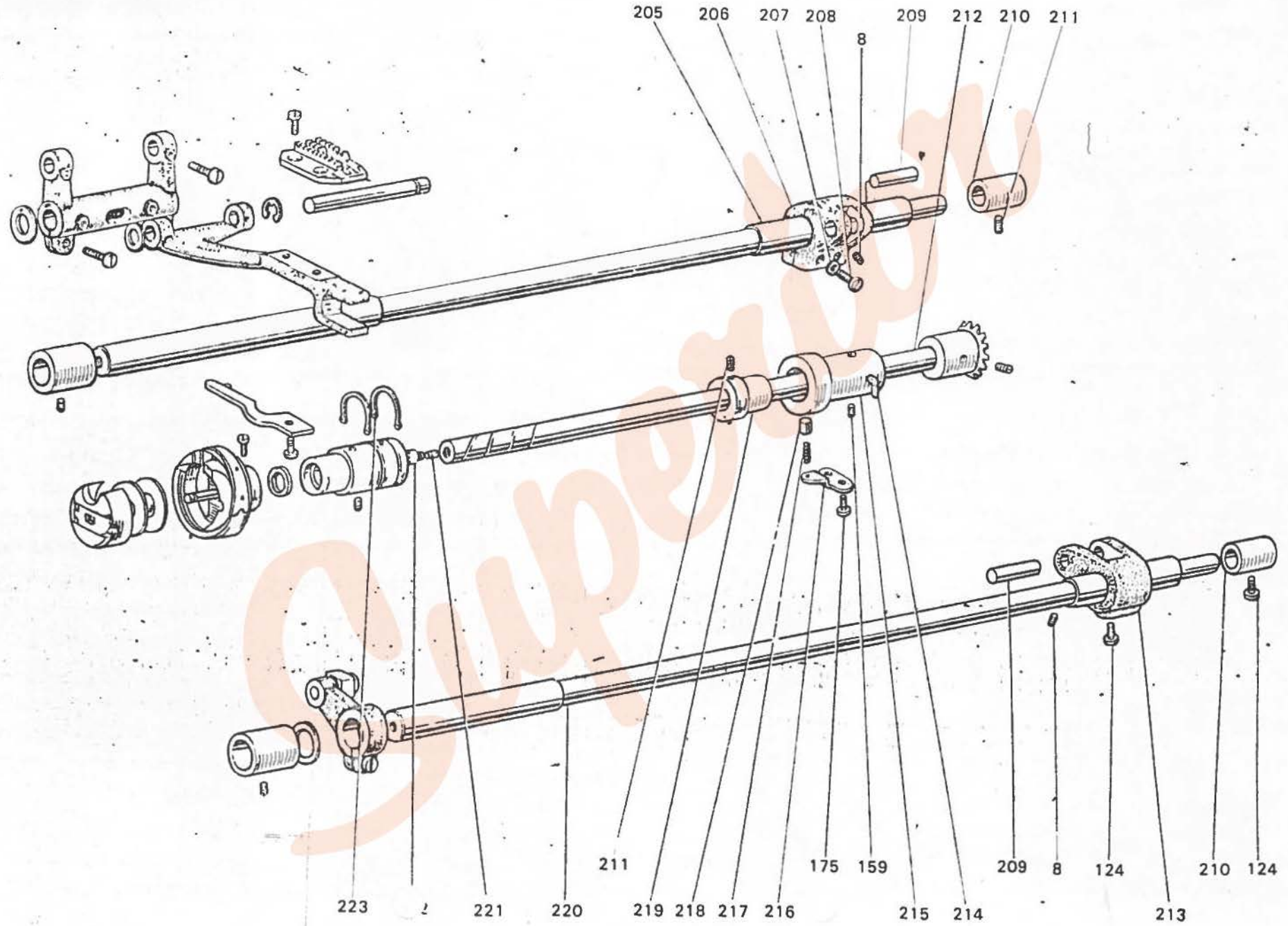

<DB189形> 下軸部分 ROTATING HOOK SHAFT MECHANISM

Fig. No.	サービス部品コード Part No.	材料コード Code No.	部 品 名	Name of Part	個/台 Amt. req							備 考 Remarks	
					DB189-10-F40A	DB189-10-F40A	DB189-11-F41D	DB189-11-F41D	DB189-12-F42B	DB189-13-F43C	DB179-F36A		
205	MF 10A0 491	W454876H01	ジク(水平送り軸)	Feed rock shaft	①	①	①	①	①	①	①	○	
206	MF 10A0 279	W447172H01	ウ デ (水平石) 右	Feed rock shaft crank (right)	①	①	①	①	①	①	①	○	
207	M9 0406 050	W470913H01	ザ ・ ガ ネ 4.5φ×84	Washer for Fig. 208	②	②	②	②	②	②	②	○	
208	M9 1113 002	W500182H01	ヒ ラ ネ ジ 11/64(40)×15	Screw for Fig. 206	②	②	②	②	②	②	②	○	
209	M9 0901 060	W501107H01	ビ ン 9.5φ×25	Set pin for feed rock crank rod	②	②	②	②	②	②	②	○	
210	MF 10A0 287	W446173H01	メタル(水平右・上下右)	Feed rock shaft bushing right	②	②	②	②	②	②	②	○	
211	M9 1506 001	B 509087H01	ト メ ネ ジ 15/64(28)×7	Set screw for Fig. 210	③	③	③	③	③	③	③	○	
212	MF 20A0 450	W460515H01	シ タ ジ ク	Rotating hook shaft	①	①	①	①	①	①	①	○	
213	MF 40A0 277	W473522H01	ウ デ (上下右)	Feed lifting rock shaft crank (right)	①	①	①	①	①	①	①	○	
214		W467871H01	バ イ プ	Oil pipe for Fig. 215	①	①	①	①	①	①	①	○	
215	MF 10A1 452	W461709H01	メタル (下軸右)	Rotating hook shaft bushing	①	①	①	①	①	①	①	○	
216	MF 10A0 154	W467869H01	アンナイイタ	Guide plate	①	①	①	①	①	①	①	○	
217	MF 20A0 572	W502769H01	ツルマキバネ	Spring for Fig. 216	①	①	①	①	①	①	①	○	
218	M9 5001 063	W461713H01	トクシュビン	Special pin for Fig. 217	①	①	①	①	①	①	①	○	
219	MF 10A0 760	W461710H01	ヘンシンリン	Eccentric link	①	①	①	①	①	①	①	○	
220	MF 10A0 460	W454877H01	ジク(上下送り軸)	Feed lifting rock shaft	①	①	①	①	①	①	①	○	
221	MF 10E3 148	W500231H01	ヒ モ 3φ×25	Oil cotton braid	①	①	①	①	①	①	①	○	
222	M9 1251 030	W500190H01	トクシュネジ 3/16(32)×6.7	Special screw	①	①	①	①	①	①	①	○	
223	M9 0320 065	S 591401H02	Cガタメワ(ジクヨウ) 20	C type stop ring	②	②	②	②	②	②	②	○	

〈DB189形〉 カマ機構部分 HOOK MECHANISM

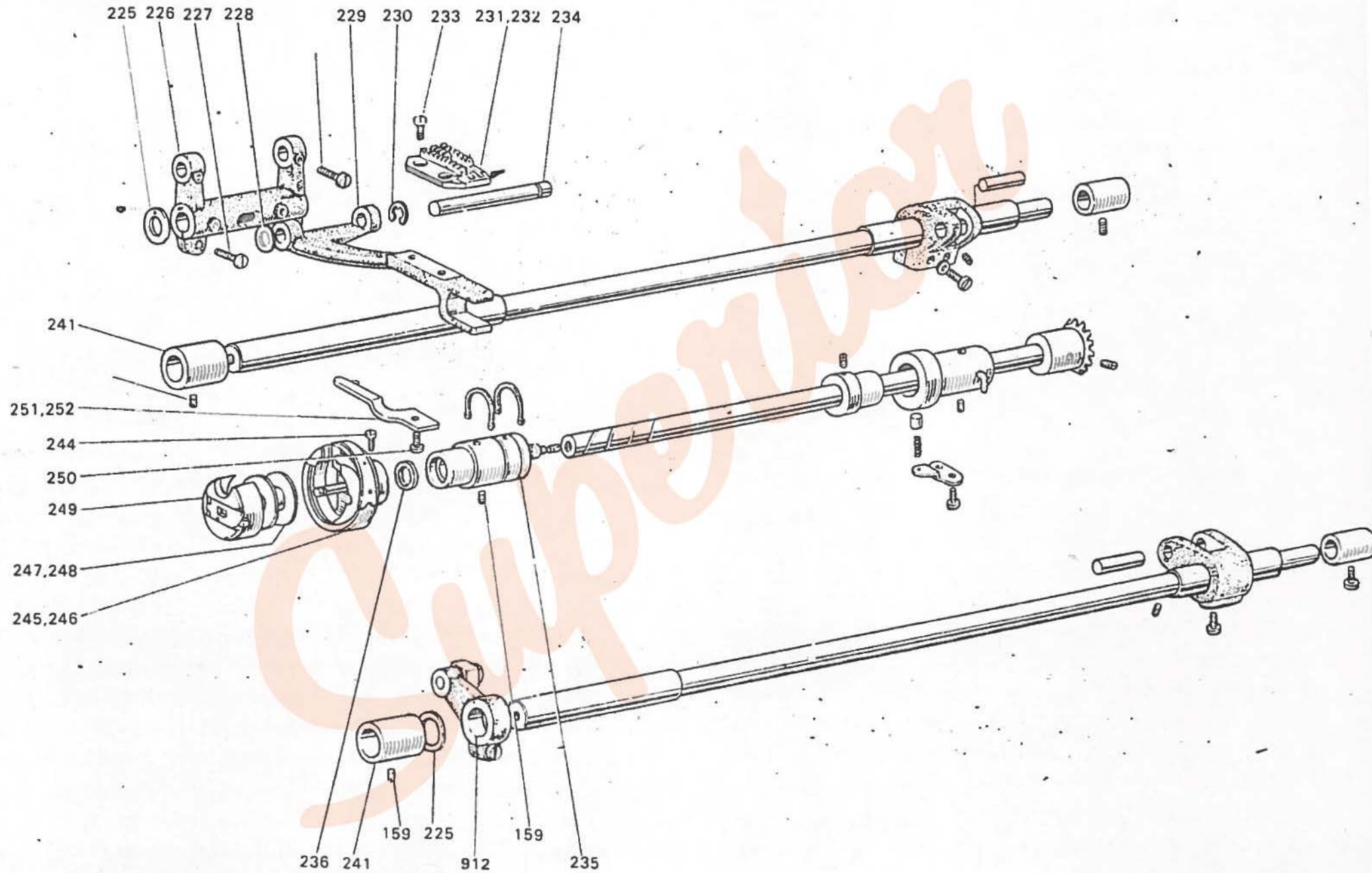

<DB189形> カマ機構部分 HOOK MECHANISM

Fig. No.	サービス部品コード Part No.	資材コード Code No.	部 品 名	Name of Part	個 / 台 Amt. req							備 考 Remarks
					DB189-10-F0A	DB189-10-F40A	DB189-11-F41D	DB189-11-F410	DB189-12-F42B	DB189-12-F43C	DB175-F26A	
225	M9 3001 052	W502467H01	ザ ガ ネ	Slide washer for Fig. 226 li	②	②	②	②	②	②		
226	MF 10A0 278	W456518H01	ウ デ (水平右)	Feed rock shaft crank (left)	①	①	①	①	①	①		
227	M9 1112 002	W501889H01	ヒ ラ ネ ジ 11/64(40)×12	Screw for Fig. 226	②	②	②	②	②	②		
228	M9 0608 050	W502480H01	ザ ガ ネ	Slide washer for Fig. 229	②	②	②	②	②	②		
229	MF 10A0 281	W447752H01	オ ク リ ダ イ	Feed bar	①	①	①	①	①	①		
230	M9 0505 065	S 592411H05	E ガ ク ト メ ウ-5	E type stop ring	①	①	①	①	①	①		
231	MF 10A0 104	W462604H01	オ ク リ	Feed dog	①	①			①	①		
232	MF 41D0 104	W461073H01	オ ク リ	Feed dog			①	①				
233	M9 0806 002	B 508857H01	ヒ ラ ネ ジ 1/8(44)×6	Screw for Figs. 232-233	③	③	③	③	③	③		
234	MF 20A0 454	W470281H01	ジ ク	Feed bar shaft	①	①	①	①	①	①		
235	MF 40A0 452	W473523H01	メタル (下前右)	Rotating hook shaft bushing (left)	①	①	①	①	①	①		
236	M9 0800 086	W465237H01	オイルシール G×8×12×3	Oil seal	①	①	①	①	①	①		
912	MF 10E0 276	W452415H01	ウデ(上下左)(組)	Feed lifting rock shaft crank Assy. (left)	①	①	①	①	①	①		
241	MF 10A0 286	W454875H01	メタル(水平右・上下右)	Feed rock shaft bushing (left)	②	②	②	②	②	②		
244	M9 1101 002	W500194H01	ヒ ラ ネ ジ 11/64(40)×4	Set screw for Figs. 245-246	②	②	①	②	②	②		
245	MF 36A0 120		カ マ HHS-12SP.	Rotating hook complete	①	①	①	①				糸切り用厚物カマ
246	MF 38B0 120		カ マ KHS-12RP	Rotating hook complete						①	①	
247	MF 36A0 123	W461729H01	ボ ビ ン	Bobbin	①	①	①			①	①	
248	MF 41D0 123	W466807H01	ボ ビ ン	Bobbin			①	①				空転防止バネ付
249	MF 36E0 125		ボビンケース	Bobbin case	①	①	①	①	①	①		
250	M9 1118 002	B 509061H01	ヒ ラ ネ ジ 11/64(40)×10	Screw for Fig. 251	①	①	①	①	①	①		
251	MF 10A0 229	W462633H01	ウチガマドメ	Rotating hook positioner	①	①	①	①				
252	MF 17B0 229	W470246H01	ウチガマドメ	Rotating hook positioner						①	①	

<DB189形> 押工機構部分 PRESSER FOOT MECHANISM

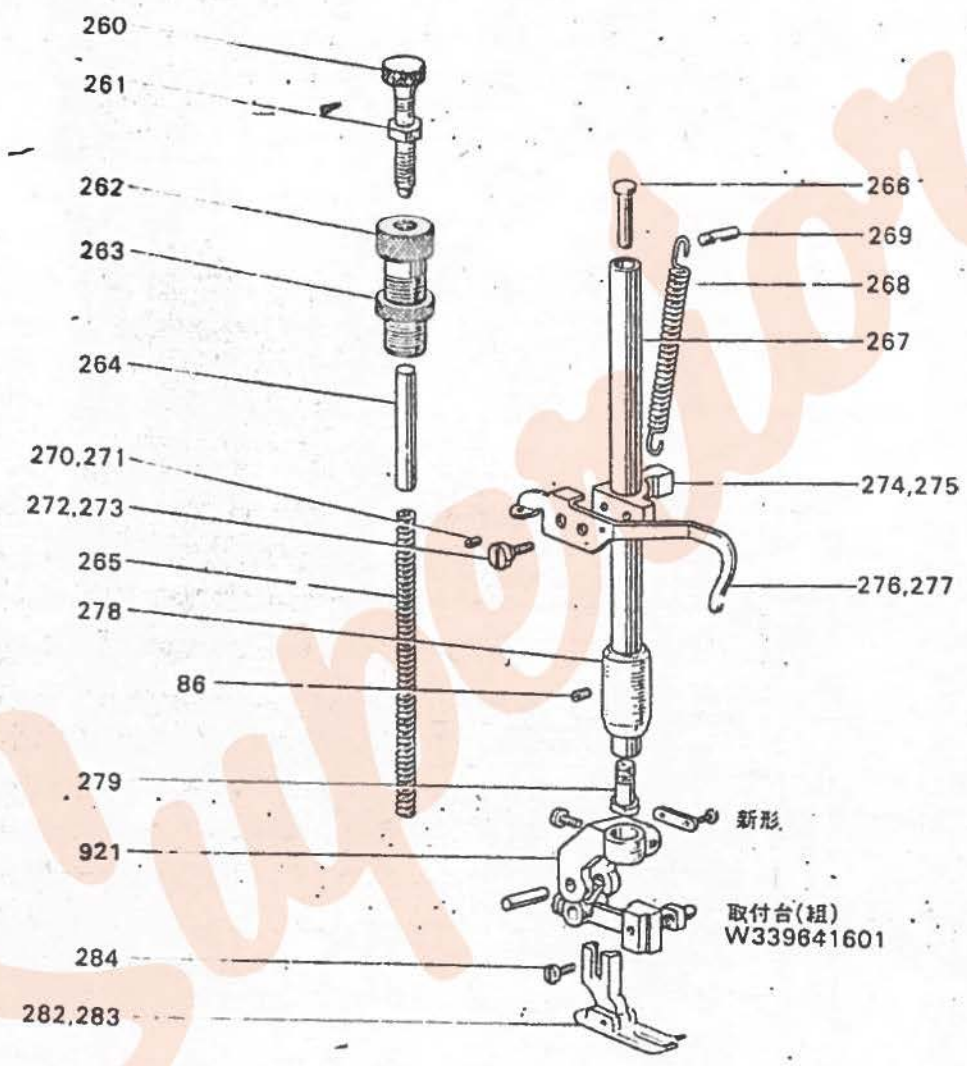

<DB189形> 押工機構部分 PRESSER FOOT MECHANISM

Fig No	サービス部品コード Part No.	資材コード Code No.	部 品 名	Name of Part	個/台 Amt. :eq							備 考 Remarks
					DB189 10-F40A	DB189 10-F40A	DB189 11F-F41D	DB189-11 F41D	DB189-12-F42B	DB189-13-F43C	DB179F36A	
260	M9 1501 035	W456548H01	ツ マ ミ ネ ジ 15/64(28)×48	Thumb screw	①	①						
261	M9 1501 045	B 509260H01	ナ ッ ト 15/64(28)	Nut for Fig. 261	①	①						
262	M9 3204 035	W456547H01	ツ マ ミ ネ ジ 1/2(28)×55	Thumb screw	①	①						
263	M9 3201 045	W471438H01	特 殊 ナ ッ ト 1/2(28)×5	Nut for Fig. 262	①	①					○	W501118
264	M9 0601 060	W474368H01	ビ ン 6φ×50	Presser bar guide	①	①						
265	MF 40A1 572	W446379H01	ツルマキバネ	Presser spring	①	①						
266	M9 0301 063	W474372H01	ダンツキピン 3φ×32	Pin	①	①						
267	MF 40A0 262	W445878H01	押 エ 棒	Presser bar	①	①						
268	MF 40A2 572	W475404H01	ツルマキバネ	Oil spring	①	①						
269	M9 0305 063	W468766H01	特 殊 ピ ン 3φ×15	Pin for Fig. 268	①	①					○	元W475403H01
270	M9 1503 001	B 508971H01	ト メ ネ ジ 15/64(28)×4.5	Screw for Fig. 274	①	①	①	①			○	
271	M9 1508 001	B 509088H01	ト メ ネ ジ 15/64(28)×7	Screw for Fig. 274					①	①	○	
272	M9 1103 016	W475402H01	ダンツキマルヒラネジ 11/64(40)×4.5	Screw for Figs. 276-277	①	①	①	①				
273	M9 1107 002	W500092H01	ヒ ラ ネ ジ 11/64(40)×5.5	Screw for Figs. 276-277					①	①	○	
274	MF 40A0 265	W475400H01	オサエボウダキ	Presser bar holder	①	①	①	①				
275	MF 20A0 265	W467222H01	オサエボウダキ	Presser bar holder					①	①		
276	MF 40A1 181	W475401H01	イトアンナイ	Thread guide	①	①	①	①				
277	MF 10A0 216	W502083H01	イトアンナイ	Thread guide					①	①	○	
278	MF 10A0 267	W502081H01	メクル (押工棒)	Presser bar bushing (lower)	①	①	①	①	①	①	○	
279	M9 1601 030	W474371H01	トクシュネジ 1/4(32)×24	Special screw for Fig. 267	①	①						
921		W339641G01	取付台 (組)		○	○						
282	MF 40A0 105	W460563G01	オサエ (組)	Presser foot	①	①	①	①				
283	MF 2300 105	W452333G01	オサエ (組)	Presser foot					①	①		
284	M9 0922 002	W464016H01	ヒ ラ ネ ジ 9/64(40)×8	Screw for Fig. 282-283	①	①	①	①	①	①	○	

<DB189形> 押工機構部分 PRESSER FOOT MECHANISM

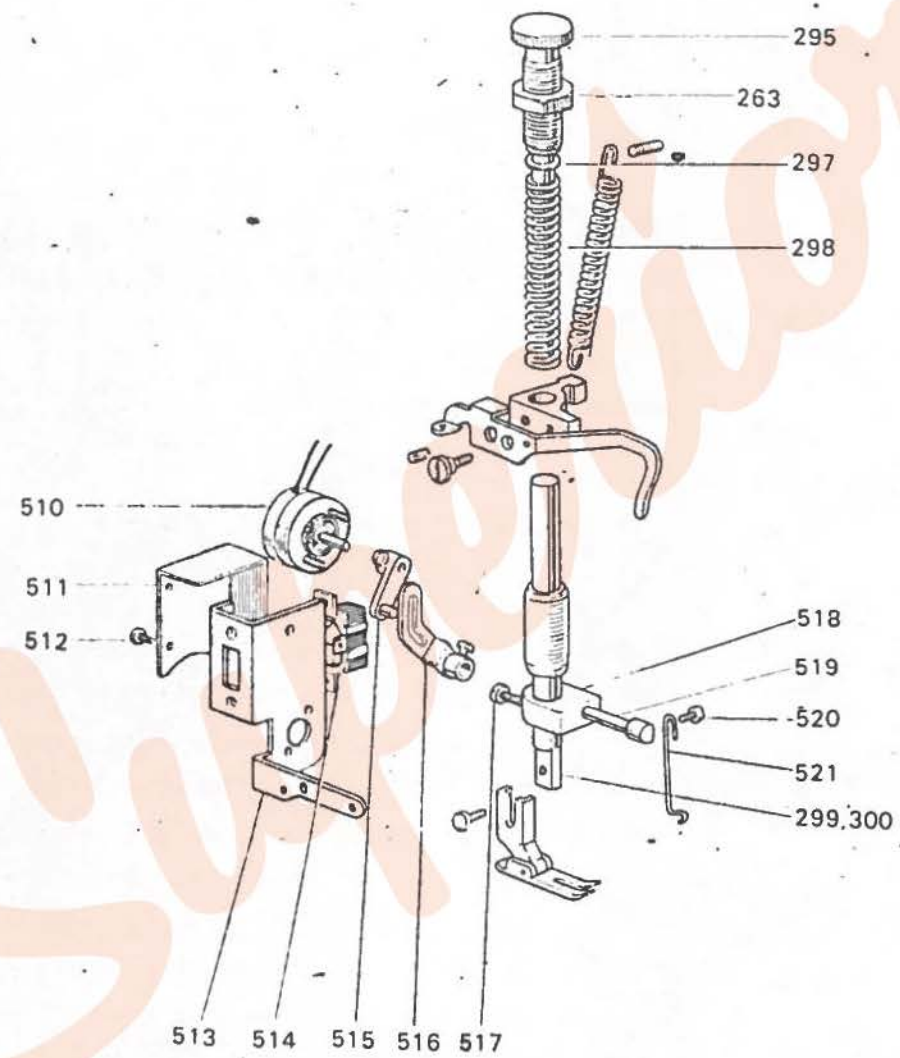

<DB189形> 押工機構部分 PRESSER FOOT MECHANISM

Fig No	サービス部品コード Part No.	資材コード Codn No.	部 品 名	Name of Part	個 / 台 Amt. req						備 考 Remarks
					DB189-10-F40A	DB189-10-F40A	DB189-11-F41D	DB189-11-F41D	DB189-12-F42B	DB189-13-F43C	
295	M9 3203 035	W475490H01	ツ マ ミ ネ ジ 1/2(28)×52	Thumb screw	○	○	○	○			
297	MF 10A0 703	W475491H01	条 内 棒	Presser for guide	○	○	○	○			
298	MF 40A3 572	W502444H01	ツルマキバネ	Presser spring	○	○	○	○			
299	MF 10A0 262	W502079H01	押 エ 棒	Presser bar	○			○	○		
300	MF 11D0 262	W502943H01	押 エ 棒	Presser bar				○			
510		P 469002X01	ロークリソレノイド				○	○			
511		W475477H01	ソレノイドカバー				○	○			
512		W509101	丸 平 ネ ジ				○	○			
513		W336689H01	ソレノイド台板				○	○			
514		S W7550	波動スイッチ				○	○			
515		W327642G01	駆動板組立				○	○			
516	MF 40E0 981	W327643G01	駆動板組立 $\phi 110$ 駆動板 (SR)				○	○			
517		W502945	平 ネ ジ				○	○			
518		W464444H01	ワイパー台				○	○			
519		W464445H01	段付ピン				○	○			
520		W501901	丸 平 ネ ジ $9/16(40) \times 6$				○	○			
521		W475475H01	ワイパー				○	○			

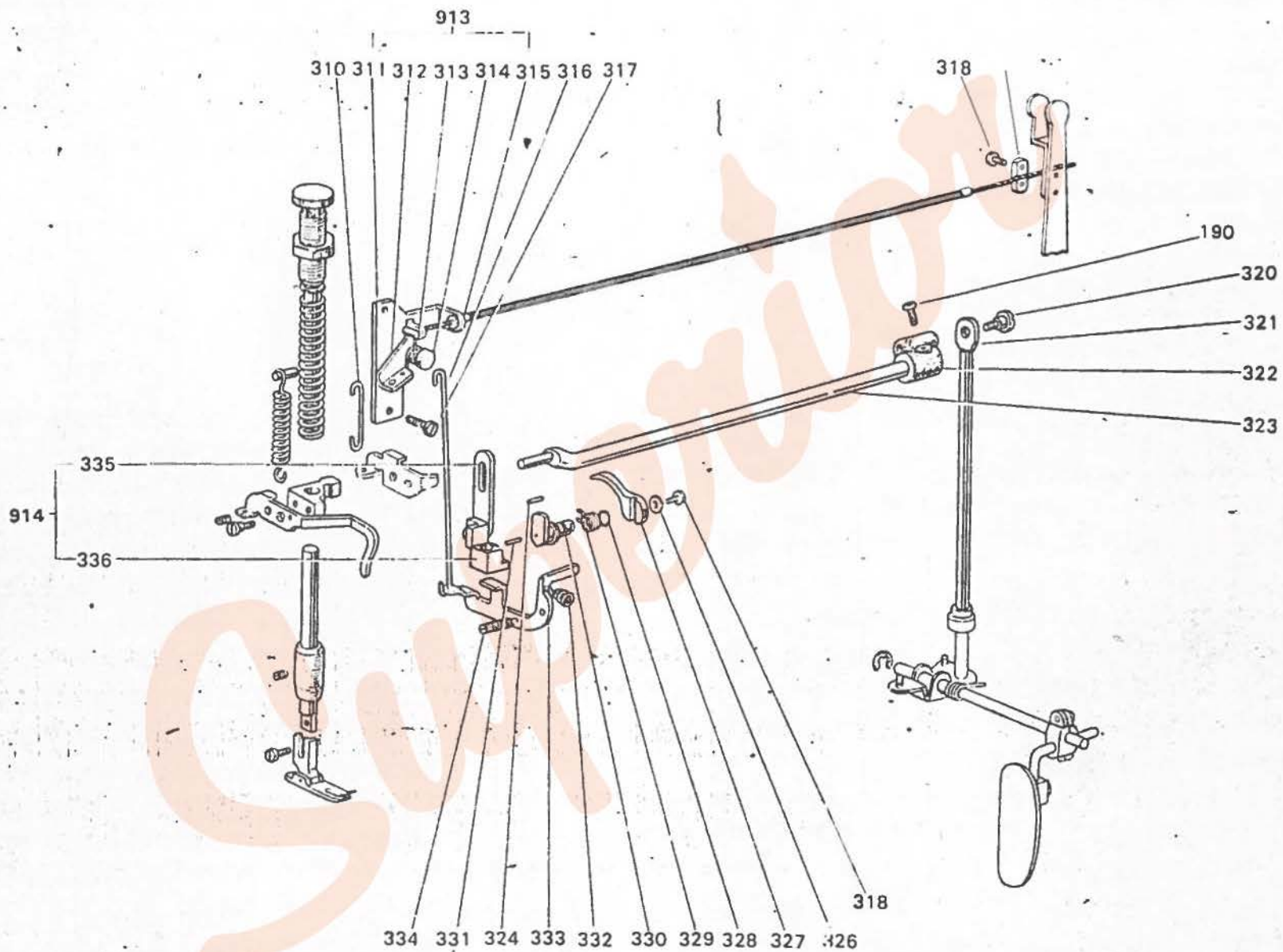

<DB189形> ソレノイド機構部分 SOLENOID MECHANISM

Fig. No.	サービス部品コード Part No.	資材コード Code No.	部 品 名	Name of Part	個 / 台 Amt. req.							備 考 Remarks
					DB189-10F-F40A	DB189-10-F40A	DB189-11F-F410	DB189-11-F410	DB189-12-F42B	DB189-13-F43C	DB175-F36A	
310	MF 40A0 680	W475405H01	ハリガネ	Steel wire	①	①	①	①	①	①		
913	MF 40E0 763	W336670G01	ベルクランク(組)	Bell crank Assy.	①	①	①	①	①	①		
311	MF 36A0 766	W460571H01	ベルクランクイタ	Bell crank plate	①	①	①	①	①	①	○	Fig.No.913ニ含ム
312	MF 40A0 763	W475407H01	ベルクランク	Bell crank	①	①	①	①	①	①		
313	MF 36A0 729	W460574H01	ヒネリバネ	Spring for Fig. 314	①	①	①	①	①	①	○	
314	M9 0403 063	W460572H01	カシメピン 4φ×21	Pin for Fig. 312	①	①	①	①	①	①	○	
315	MF 40A0 746	W473527H01	フレキシブルワイヤ	Flexible wire	①	①	①	①	①	①		
316	MF 36A0 680	W460575H01	ハリガネ	Steel wire	①	①	①	①	①	①	○	
317	M9 1104 002	B.503842H01	ヒラネジ 11/64(40)×4.5	Screw for Fig. 311	②	②	②	②	②	②	○	
318	M9 0921 002	B 508848H01	ヒラネジ 9/64(40)×8	Screw for Figs. 327 & 319	③	③	③	③	③	③	○	
319	MF 36A0 750	W502917H01	ブッシュ	Bushing (rear)	①	①	①	①	①	①	○	
320	M9 1504 015	W502104H01	ヒラネジダンツキ 15/64(28)	Screw for Fig. 321	①	①	①	①	①	①	○	
321	MF 20A0 511	W470289H01	ソウサボウ	Knee lifter lever connecting rod	①	①	①	①	①	①		
322	MF 40A0 228	W473525H01	ウデ	Knee lifter crank	①	①	①	①	①	①		
323	MF 40A0 382	W473524H01	クランクジク	Knee lifter lever	①	①	①	①	①	①		
324	M9 0304 060	W501874H01	ピン 3φ×12	Stopper pin	①	①	①	①	①	①		
326	M9 0401 053	S 561121H03	バネザガネ 4	Washer for Fig. 318	①	①	①	①	①	①	○	
327	MF 10A0 252	W447053H01	レバー(押エアゲ)	Presser bar lifter	①	①	①	①	①	①	○	
328	M9 0400 085	S 648001H02	Oリング 1A P4	O-ring for Fig. 330	①	①	①	①	①	①	○	
329	MF 10A0 729	W502141H01	ヒネリバネ	Spring for Fig. 330	①	①	①	①	①	①	○	
330	MF 36A0 253	W464472H01	オサエアゲカム	Presser bar lifter cam	①	①	①	①	①	①	○	
331	M9 0211 060	W470270H01	ピン 2φ×16	Stopper pin	①	①	①	①	①	①		
332	MF 10A2 245	B 409092H01	エンスイバネ	Spring for Fig. 333	①	①	①	①	①	①	○	
333	MF 36A0 220	W464055H01	フワイトコルメ	Set screw for Fig. 333	①	①	①	①	①	①	○	
334	M9 1102 033	W502123H01	ピンネジ 11/64(40)×23.5	Presser bar lifter Assy.	①	①	①	①	①	①	○	
914	MF 40E0 264	W327610G01	オサエボウアゲ(組)	Knee lifter lever link	①	①	①	①	①	①		
335	MF 10A0 720	W502084H01	ヒキアゲイタ	Knee lifter lever link	①	①	①	①	①	①	○	Fig.No.914ニ含ム
336	MF 10A0 475	W450066H01	スベリアゲ	Slide block	①	①	①	①	①	①	○	

〈DB189〉 ソレノイド機構部分 SOLENOID MECHANISM

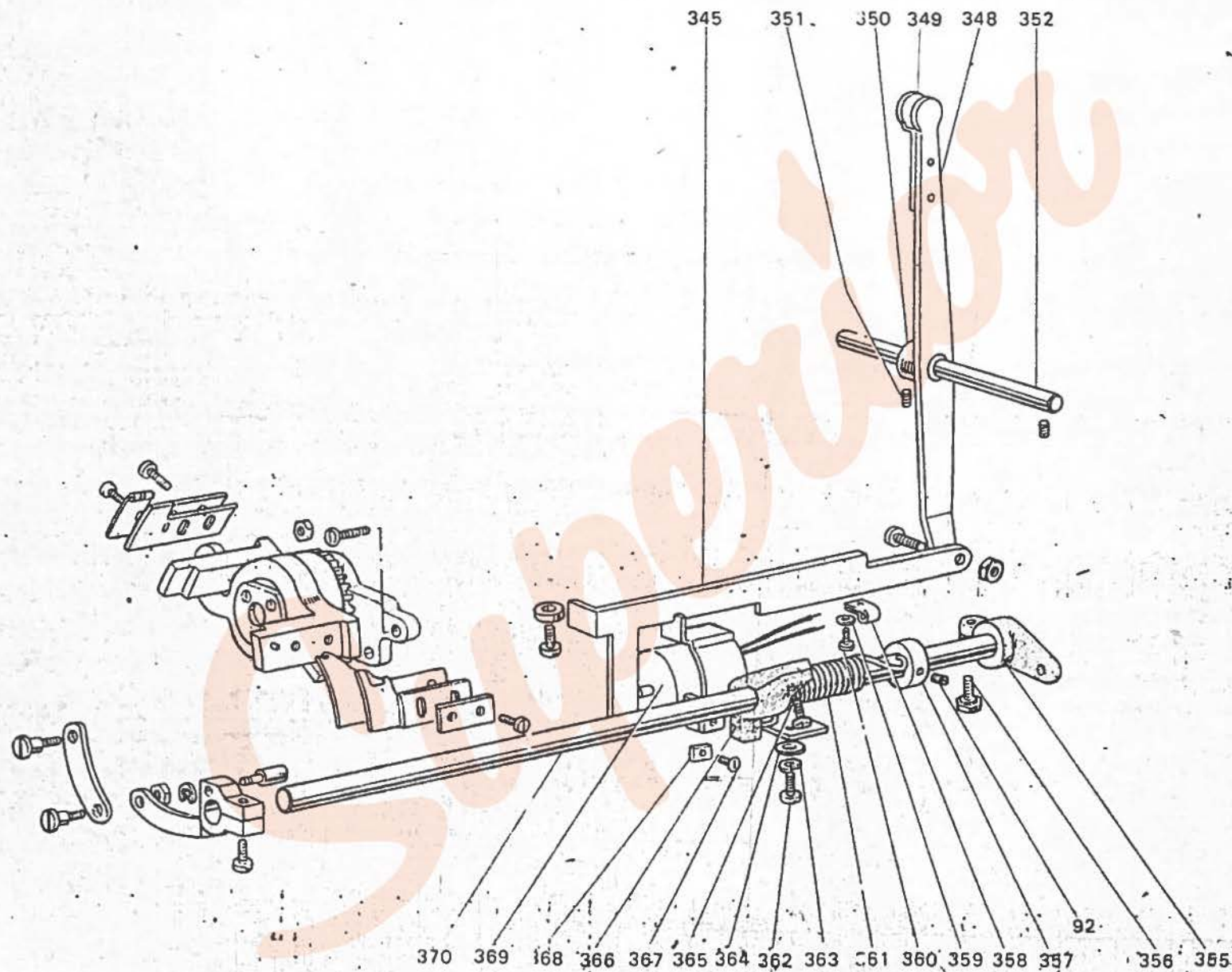

<DB189形> メス機構部分 KNIFE MECHANISM

Fig No	サービス部品コード Part No.	資材コード Code No	部 品 名	Name of Part	個/台 Amt. req							備 考 Remarks	
					DB189-10-F40A	DB189-10-F40A	DB189-11-F41D	DB189-11-F41D	DB189-12-F42B	DB189-13-F43C	DB179-F36A		
345	MF 40A0 910	W473526H01	リ ン ク	Connecting link	①	①	①	①	①	①	①		
348	MF 40A0 590	W331460H01	テ コ	Lever (large)	①	①	①	①	①	①	①		
349		W460550H01	テ コ (小)	Lever (small)	①	①	①	①	①	①	①		Fig.No.348ニ含ム
350		W502915H01	ブ ッ シ ュ	Bushing for Fig. 352	①	①	①	①	①	①	①		
351	M9 1110 001	B 509339H01	ト メ ネ ジ 11/64(40)×8.5	Set screw for Fig. 350	①	①	①	①	①	①	①		
352	MF 36A0 592	W460551H01	テ コ ジ ャ	Lever stud	①	①	①	①	①	①	①		
353	M9 1212 015	W501778H01	ヒラネジダツキ 3/16(28)	Hinge screw for Figs. 348 & 345	①	①	①	①	①	①	①		
354	M9 1201 045	W501827H01	ナ ッ ト 3/16(28)	Nut for Fig. 353	①	①	①	①	①	①	①		
355	MF 40A1 228	W473533H01	ウ デ	Vibrating crank	①	①	①	①	①	①	①		
356	M9 0602 031	W468547H01	ミゾツキボルト 1/4(40)×13	Screw	②	②	②	②	②	②	②		
357	MF 10A0 352	B 422844H01	カ ラ ー	Collar	①	①	①	①	①	①	①		
358	M9 4004 099	S 452001H03	ナイロンクリップ HP-4N	Nylon clip	①	①	①	①	①	①	①		
359	M9 0501 050	W500384H01	ザ ガ ネ	Washer for Fig. 360	①	①	①	①	①	①	①		
360	M9 0921 002	B 508848H01	ヒ ラ ネ ジ 9/64(40)×8	Screw for Fig. 358	①	①	①	①	①	①	①		
361	MF 40A4 572	W471450H01	ヒネリツルマキバネ	Coil spring	①	①	①	①	①	①	①		
362	M9 1118 002	B 509061H01	ヒララ ネ ジ 11/64(40)×10	Screw	④	④	④	④	④	④	④		
363	M9 0501 053	S 561121H04	バネザガネ 5	Spring washer for Fig. 362	⑤	⑤	⑤	⑤	⑤	⑤	⑤		
364	M9 0504 050	W462719H01	ザガネ(小形丸5) M5	Washer for Fig. 362	④	④	④	④	④	④	④		
365	M9 1117 002	B 503844H01	ヒ ラ ネ ジ 11/64(40)×13	Screw for Fig. 366	①	①	①	①	①	①	①		
366	MF 36A0 477	W460529H01	ス ト ッ パ ー	Stopper	①	①	①	①	①	①	①		
367	M9 0604 011	W501205H01	マルサラネジ 3/32(56)×4	Screw	①	①	①	①	①	①	①		
368	MF 36A0 618	W460531H01	ナイロンイタ	Nylon plate	①	①	①	①	①	①	①		
369	M9 1002 098	W331481G01	ソレノイド (組)	Solenoid assembly	①	①	①	①	①	①	①		
370	MF 40A2 454	W473534H01	ジ ャ ク	Knife driving shaft	①	①	①	①	①	①	①		

〈DB189形〉 メス機構部分 KNIFE MECHANISM

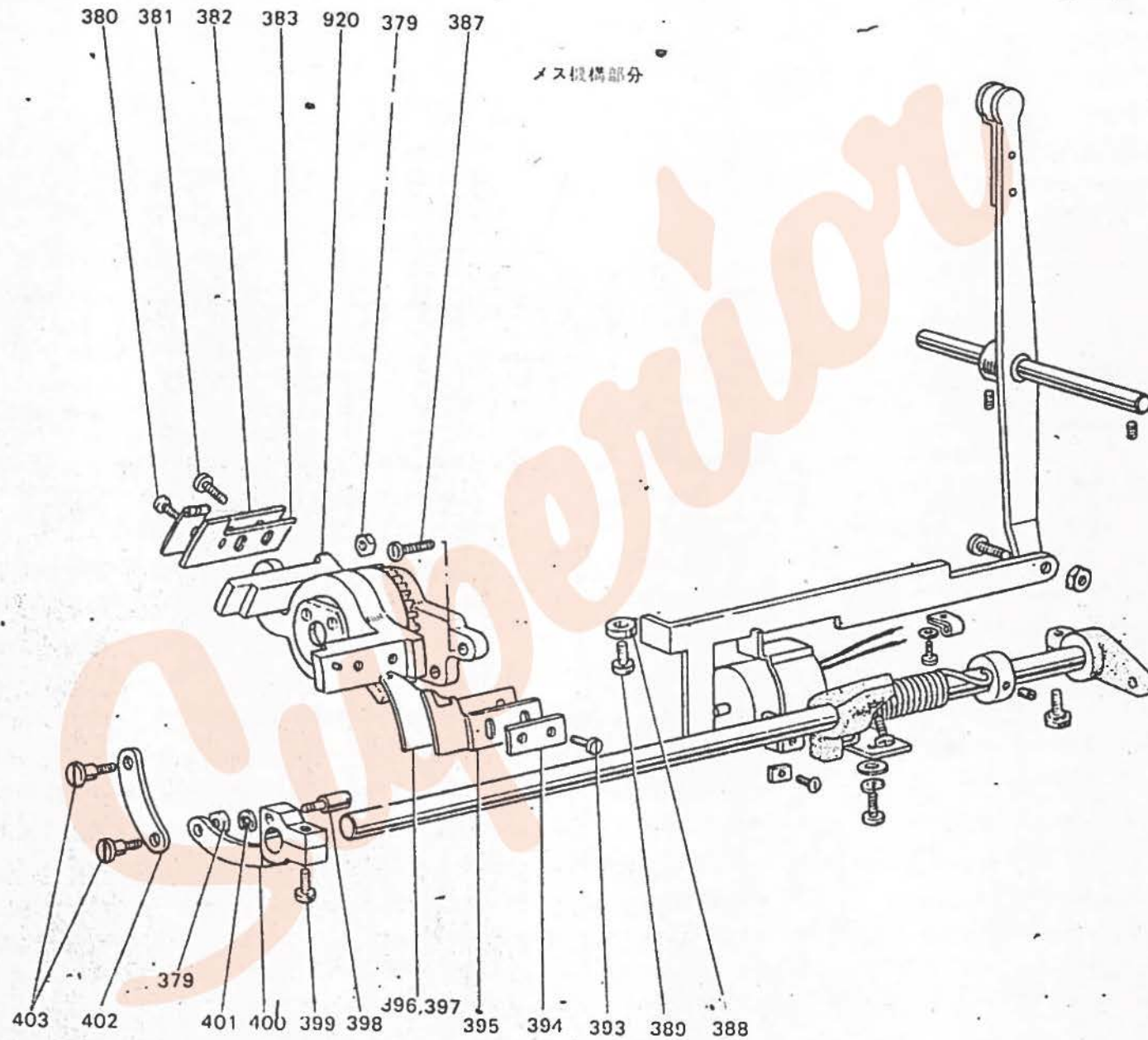

<DB189形> カム軸部分- CAM SHAFT MECHANISM

Fig. No.	サービス部品コード Part No	資材コード Code No.	部 品 名	Name of Part	個 / 台 Amt. req							備 考 Remarks
					DB189-10-F40A	DB189-10-F41D	DB189-11-F41D	DB189-11-F41D	DB189-12-F42B	DB189-12-F42C	DB179-F36A	
379	M9 1107 045	W475413H01	ナ ッ ト 11/64(40)	Nut for Fig. 377	2	2	2	2	2	2		
380	M9 0805 003	W473537H01	マルヒラネジ 1/8(44)×4.5	Screw	1	1	1	1	1	1		
381	M9 0803 003	W502920H01	マルヒラネジ 1/8(40)×6	Screw	2	2	1	2	2	2	0	
382	MF 40A0 782	W473536H01	ホ ゴ イ タ	Guard plate	1	1	0	1	1	1		
383	MF 40A0 834	W473535H01	メ ス (ヒタリ)	Knife (loft)	1	1	1	1	1	1		
920			上メス機構部分組立		0	0	0	0	0	0	0	
387	M9 1503 003	W501002H01	マルヒラネジ 15/64(28)×13	Set screw for Fig. 386	2	2	2	2	2	2		
388	MF 36A0 478	W502346H01	ストッパーリング	Stopper ring	1	1	1	1	1	1	0	
389	M9 0903 002	B 509065H01	ヒ ラ ネ ジ 9/64(40)×6.5	Screw for Fig. 388	1	1	1	1	1	1	0	
393	M9 0803 003	W502920H01	マルヒラネジ 1/8(44)×6	Screw	2	2	2	2	2	2	0	
394	M9 5001 052	W460580H01	特 殊 座 金	Washer	1	1	1	1	1	1	0	
395	MF 36A0 835 ²	W460520H01	メ ス (ミギ)	Knife (right)	1	1	1	1	1	1	0	
396	MF 36A0 782	W462899H01	イトアンナイ	Thread guide for knife	1	1	1	1			0	
397	MF 40A0 180	W465383H01	イトアンナイ	Thread guide for knife					1	1		18 = MF 40A0 180 (with 40A0 180)
398	MF 36A0 411	W502913H01	コ ロ	Hinge stud	1	1	1	1	1	1	0	
399	M9 1117 002	B 503844H01	ヒ ラ ネ ジ 11/64(40)×13	Screw	1	1	1	1	1	1	0	
400	MF 40A0 392	W475410H01	クドウウデ	Feed rock shaft crank	1	1	1	1	1	1		
401	M9 0501 065	S-592411H01	E ガクトメワ 2	E- washer	1	1	1	1	1	1		
402	MF 40A1 910	W475411H01	リ ン ク	Link	1	1	1	1	1	1		
403	M9 0202 099	W475412H01	ヒラネジダンソキ 11/64(40)	Set screw for Fig. 402	1	1	1	1	1	1		

<DB189形> カム軸部分 CAM SHAFT MECHANISM

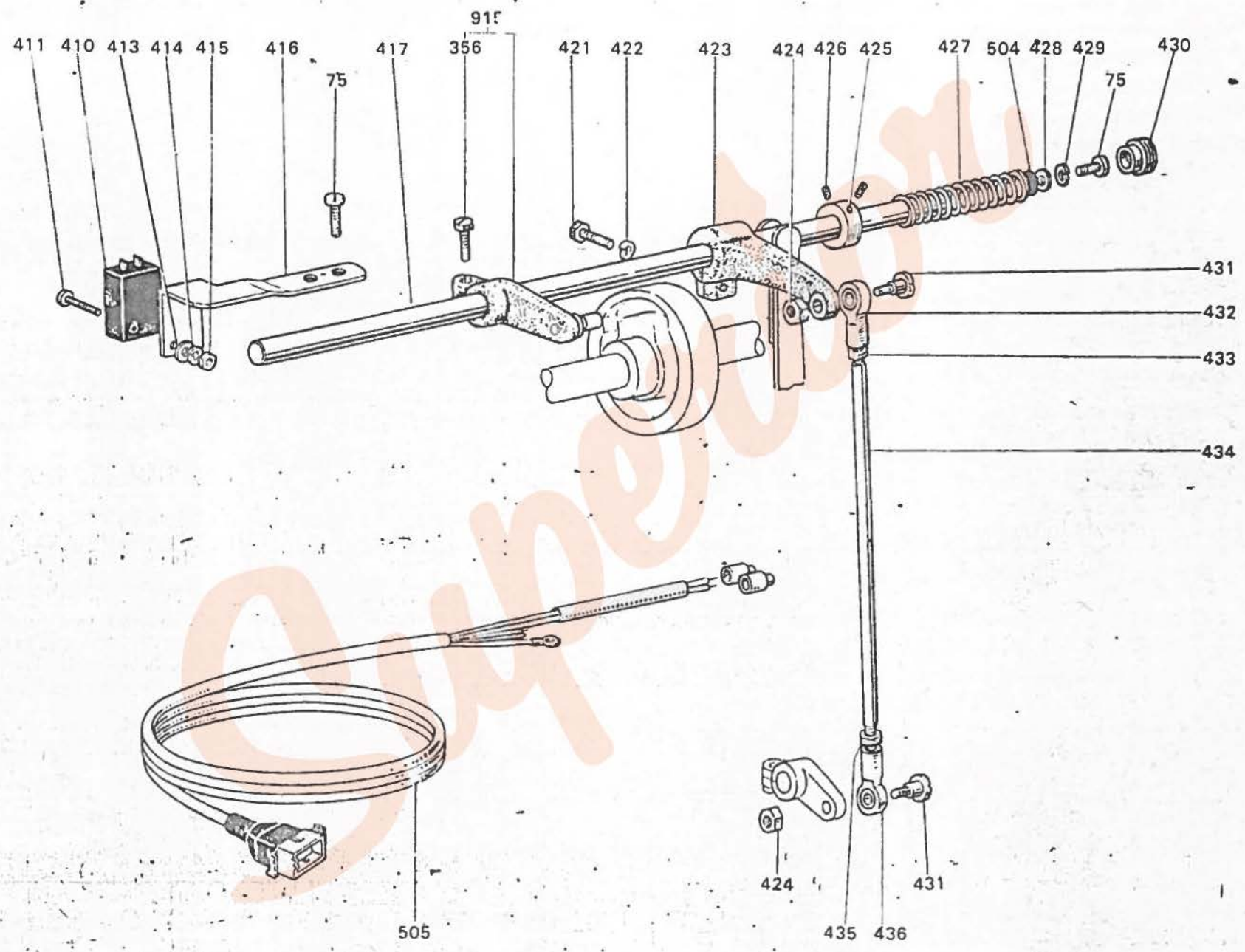
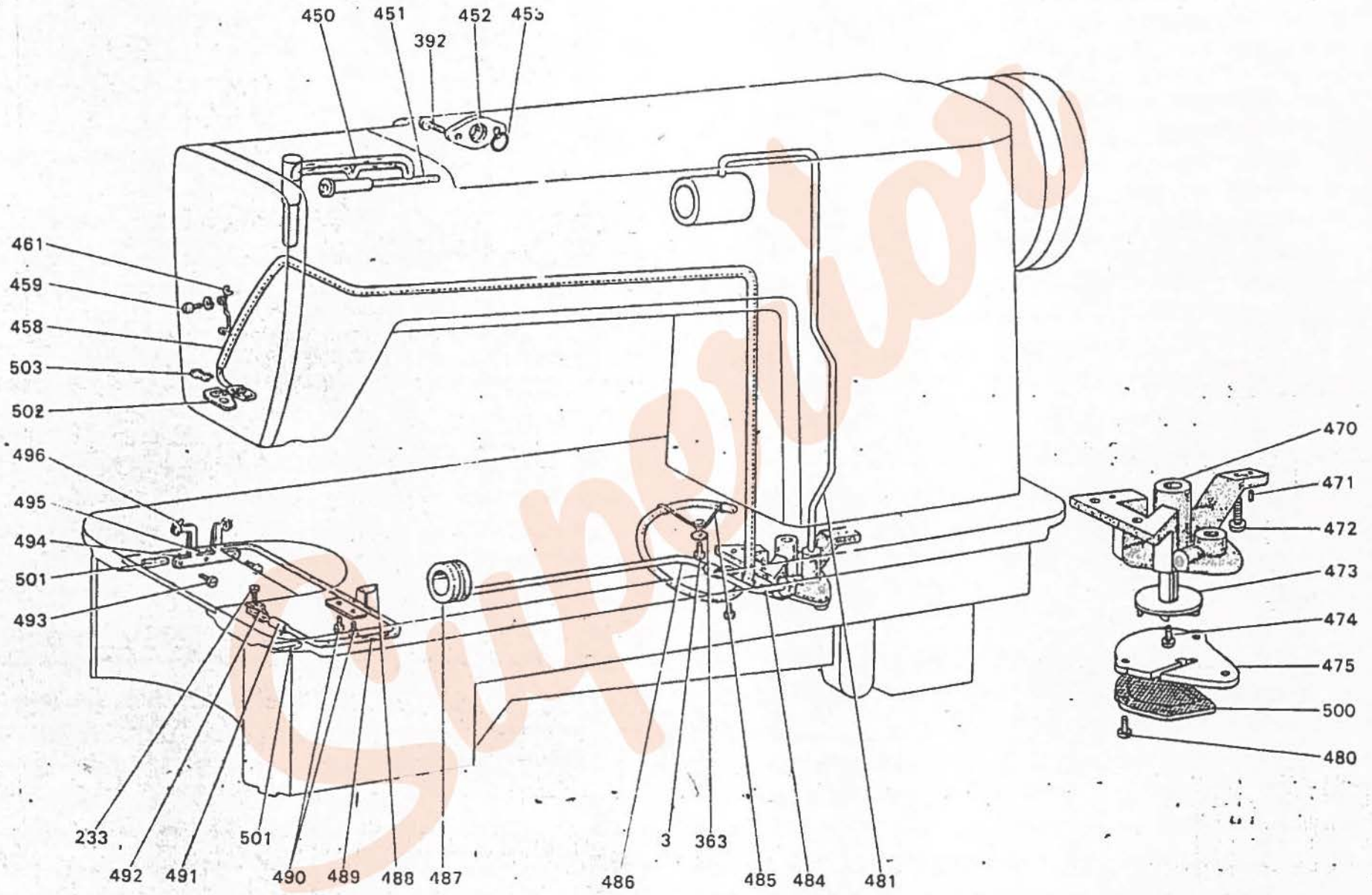

Fig No	サービス部品コード Part No.	資材コード Code No.	部 品 名	Name of Part	個 / 台 Amt. req							備 考 Remarks	
					DB189-10F-F40A	DB189-10-F40A	DB189-11F-F41D	DB189-11-F41D	DB189-12-F42B	DB189-13-F42C	DB179-F26A		
410	M9 0202 099		マイクロスイッチ VL-12	Micro switch	①	①	①	①	①	①	①	①	
411	M9 0320 037		P ナベネジ M3×20	Screw for Fig. 410	②	②	②	②	②	②	②	②	
413	M9 0501 050	W500384H01	ザ ガ ネ 5	Washer for Fig. 411	②	②	②	②	②	②	②	②	
414	M9 0301 053	S 561121H01	バネザガネ 3	Spring washer for Fig. 411	③	③	③	③	③	③	③	③	
415	M9 0871 045	S 541111H10	ナ ッ ト M3	Nut for Fig. 411	②	②	②	②	②	②	②	②	
416	MF 36A1 601	W462647H01	スイッチトリツケイタ	Switch supporting plate	①	①	①	①	①	①	①	①	
417	MF 40A0 348	W473528H01	カム ジ ャク	Cam shaft	①	①	①	①	①	①	①	①	
915	MF 40E0 228		ウ デ (組)	Cam drive crank Assy.	①	①	①	①	①	①	①	①	
421	M9 1506 022	W501545H01	ボ ル ト 15 64(28)×16	Bolt for Fig. 423	①	①	①	①	①	①	①	①	
422	M9 0601 053	W561121H05	バネザガネ 6	Spring washer for Fig. 423	①	①	①	①	①	①	①	①	
423	MF 40A2 228	W473531H01	ウ デ	Knife drive crank	①	①	①	①	①	①	①	①	
424	M9 1104 045	W500079H01	ナ ッ ト 11/64(40)×3	Nut for Fig. 431	②	②	②	②	②	②	②	②	
425	MF 36A1 352	W468250H01	カ ラ ー	Collar for Fig. 348	①	①	①	①	①	①	①	①	
426	M9 1106 001	B 509266H01	ト メ ネ ジ 11/64(40)×4.3	Set screw for Fig. 425	②	②	②	②	②	②	②	②	
427	MF 40A5 572	W473529H01	ツルマキバネ	Coil spring	①	①	①	①	①	①	①	①	
428	M9 0407 050	W469519H01	ザ ガ ネ 4.6	Washer	①	①	①	①	①	①	①	①	
429	M9 0501 053	S 561121H04	バネザガネ 5	Spring washer	②	②	②	②	②	②	②	②	
430	M9 1600 080	W476428H01	ゴ ム セ ン 16φ	Roller plug	①	①	①	①	①	①	①	①	
431	M9 1101 015	W502907H01	ヒラネジダンツキ 11/64(40)×17	Hinge screw	②	②	②	②	②	②	②	②	
432	MF 36A0 785		ボールジョイント TF-5	Connecting link	①	①	①	①	①	①	①	①	
433	M9 1371 045		ナ ッ ト M5	Nut for Fig. 434	①	①	①	①	①	①	①	①	
434	M9 5001 023	W473532H01	ウエコミボルト M5×187	Connecting rod	①	①	①	①	①	①	①	①	
435	M9 1381 045		ナ ッ ト (左) M5	Nut for Fig. 434	①	①	①	①	①	①	①	①	
436	MF 36A0 786		ボールジョイント TFL-5	Connecting link for Fig 434	①	①	①	①	①	①	①	①	
504		W479304H01	座 金		①	①	①	①	①	①	①	①	
505		W479309G01	コ ー ド 組 立		①	①	①	①	①	①	①	①	

<DB189形> 給油機構部分 OIL IUBRICATION MECHANISM



<DB189形> 給油機構部分 OIL LUBRICATION MECHANISM

Fig No	サービス部品コード Part No.	資材コード Codo No.	部 品 名	Name of Part	個/台 Amt. req							備 考 Remarks
					DB189-10F-F40A	DB189-10-F40A	DB189-11F-F41D	DB189-11-F41D	DB189-12-F42B	DB189-13-F43C	DB176-F45A	
450	MF 10E2 148	W444138H01	ヒ モ	Oil cotton braid	①	①	①	①	①	①		
451	MF 10E2 148	W462729H01	ヒ モ	Oil cotton braid	①	①	①	①	①	①		
452	MF 36A0 257	W466229H01	オ サ エ イ タ	Stopper plate	①	①	①	①	①	①		
453	M9 0600 085	S 648001H01	オ リ ン グ 1A P6	O-ring	①	①	①	①	①	①		
458	MF 36A1 731	W467876H01	バ イ プ	Oil pipe	①	①	①	①	①	①		
459	M9 1108 002	B 509289H01	ヒ ラ ネ ジ 11/64(40)×7	Screw for Fig. 461	①	①	①	①	①	①		
461	MF 36A0 689	W470900H01	ホ ル ダ	Oil pipe holder	①	①	①	①	①	①		
470	MF 40A0 747	W225187H01	フ レ ー ム	Oil pump body	①	①	①	①	①	①		
471	M9 0202 061	W500212H01	テ ー バ ビ ン 2.5φ×12×1/50	Oil pump positioning pin	①	①	①	①	①	①		
472	M9 1103 004	W467868H01	ブラマイネジ 11/64(40)×13	Screw for Fig. 470	③	③	③	③	③	③		
473	MF 10A0 685	W470288H01	ハネグロマ	Oil pump impeller	①	①	①	①	①	①		
474	M9 0810 002	W501133H01	ヒ ラ ネ ジ 1/8(44)×8	Screw for Fig. 473	①	①	①	①	①	①		
475	MF 10A0 601	W461088H01	トリツケイク	Oil suction plate	①	①	①	①	①	①		
476	MF 10A0 337	W502363H01	ア ミ BS	Oil pump screen	①	①	①	①	①	①		
477	MF 10A0 338	W502362H01	オ サ エ イ タ	Oil pump screen cover	①	①	①	①	①	①		
478	MF 10A1 742	W470250H01	フ タ	Oil adjusting plate	①	①	①	①	①	①		
479	M9 0402 053	W500297H01	バネザガネ	Spring washer for Fig. 480	①	①	①	①	①	①		
480	M9 0801 004	W467881H01	ブラマイネジ 1/8(44)×13	Screw for Fig. 478	③	③	③	③	③	③		
481	MF 40E0 143	W335905H01	パイプ (上) 組	Oil pipe for arm shaft	①	①	①	①	①	①		
484	MF 40E0 144	W335906H01	パイプ (下) 組	Oil pipe for hook shaft	①	①	①	①	①	①		
485	MF 40A0 780	W467872H01	ホ ル ダ	Oil pipe holder for Fig. 458	①	①	①	①	①	①		
486	MF 40A1 780	W467873H01	ホ ル ダ	Oil pipe holder for Fig. 458	①	①	①	①	①	①		
487	MF 20A0 631	W470287H01	ダ イ ヤ ル	Oil adjustable ring	①	①	①	①	①	①		
488	MF 10A0 477	W502095H01	ス ト ッ パ ー	Stopper for Fig. 487	①	①	①	①	①	①		
489	MF 10E2 148	W466814H01	ヒ モ	Oil cotton braid	①	①	①	①	①	①		
490	M9 0906 002	W500791H01	ヒ ラ ネ ジ 9.64(40)×4.5	Screw for Fig. 488	②	②	②	②	②	②		
491	MF 40A1 140	W501450H01	バ イ プ	Oil cotton braid holder pipe	①	①	①	①	①	①		
492	MF 10A0 780	W444282H01	ホ ル ダ	Oil cotton braid holder	①	①	①	①	①	①		
493	M9 1104 002	B 503842H01	ヒ ラ ネ ジ 11/64(40)×4.5	Set screw for Fig. 494	②	②	②	②	②	②		
494	MF 10A0 147	W447762H01	ホ ル ダ	Oil cotton braid supporter	①	①	①	①	①	①		
495	MF 40A0 140	W462831H01	バ イ プ	Oil cotton braid pipe	①	①	①	①	①	①		
496	MF 10E3 148	W462830H01	ヒ モ	Oil cotton braid	①	①	①	①	①	①		
500	MF 10E0 337	3 01	ア ミ 組 立		○	○	○	○	○	○		
501		W462830H01	油 ヒ モ		○	○	○	○	○	○		
502	MF 10A0 740	W479326G01	フェルト組立		○	○	○	○	○	○		
503		W479329H01	フェルト押エ		○	○	○	○	○	○		

<DB189形> 付属品箱 ACCESSORIES BOX

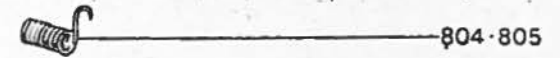
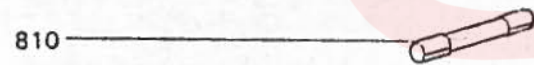
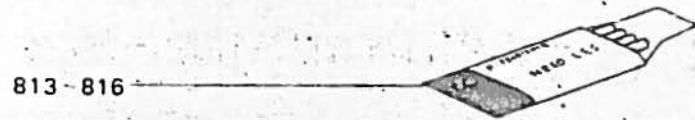
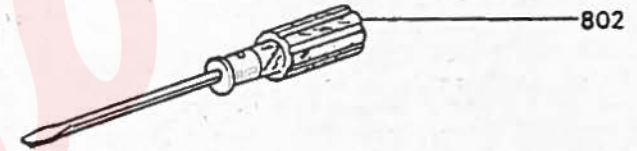
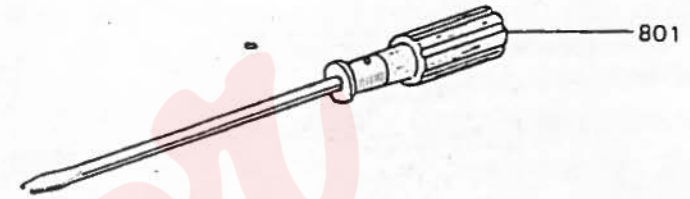
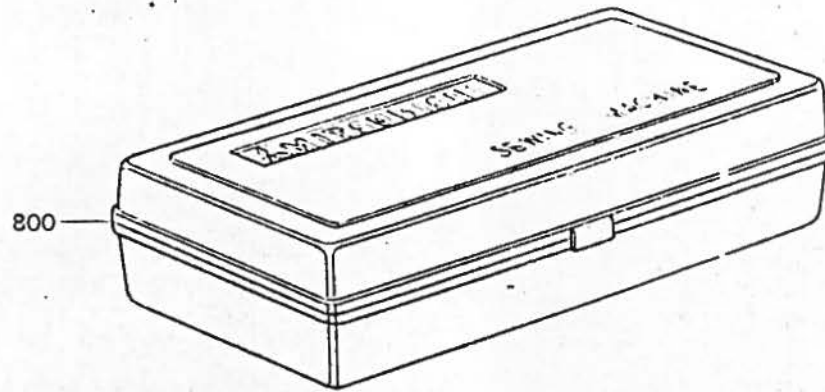

〈DB189形〉 付属品 ACCESSORIES

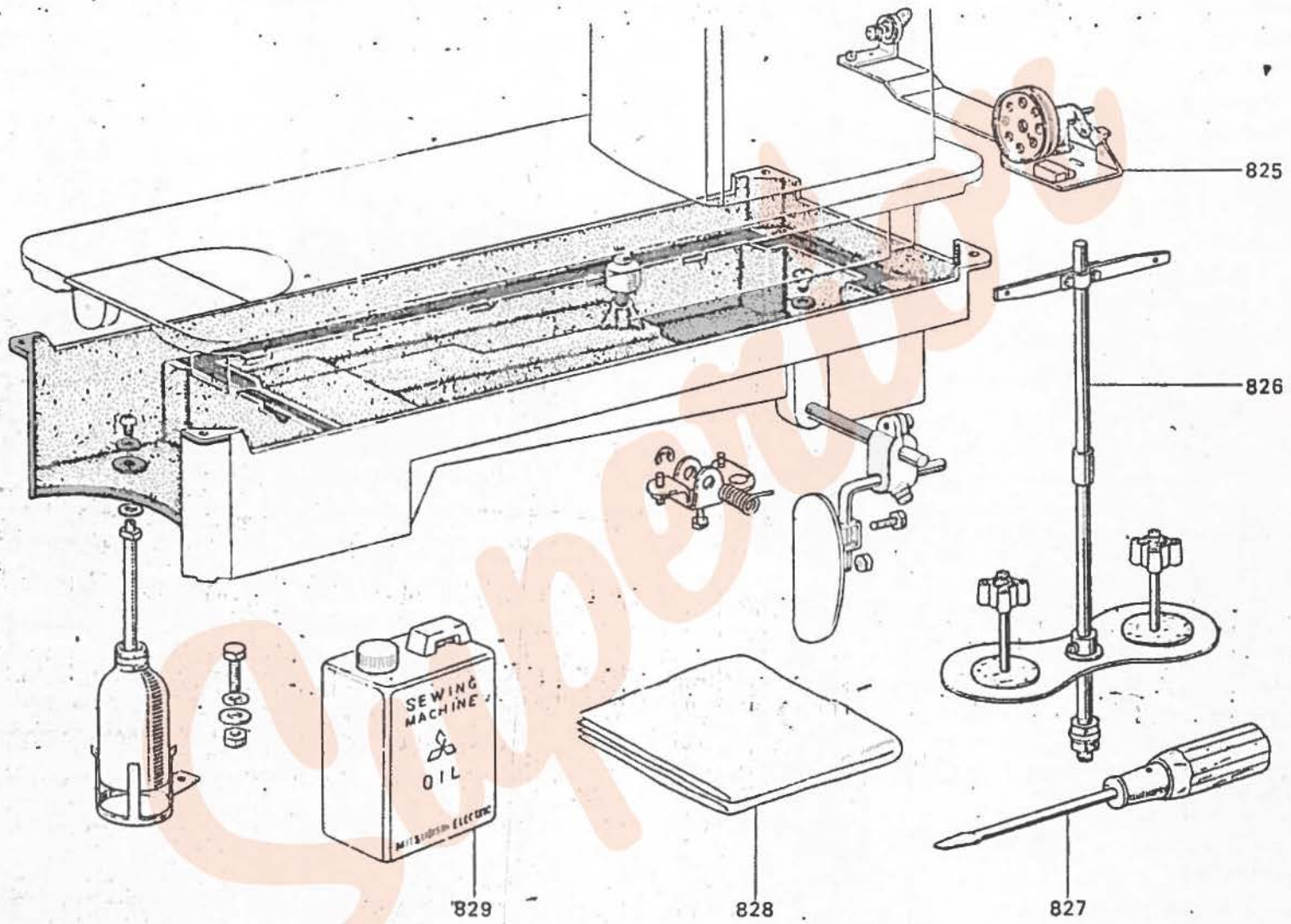

<DB189形> 付属品---ACCESSORIES

Fig No	サービス部品コード Part No.	資材コード Code No.	部 品 名	Name of Part	個 / 台 Amt. req							備 考 Remarks	
					DB189-10-F40A	DB189-10-F40A	DB189-11-F41D	DB189-11-F41D	DB189-12-F42B	DB189-13-F43C	DB179-F3A		
825	MF 20EO 190 93	SM31097G01	イトマキンカケ (組)	Bobbin winder	(1)	(1)	(1)	(1)	(1)	(1)	(1)	(1)	
826	MF 40EO 168	W227464G01	イトタテグイ (組)	Cotton stand	(1)	(1)	(1)	(1)	(1)	(1)	(1)	(1)	
827		W319408H01	ネジワマシ (大)	Screw driver (large)	(1)	(1)	(1)	(1)	(1)	(1)	(1)	(1)	
828		W220627H01	ビニールカバー	Vinyl cover	(1)	(1)	(1)	(1)	(1)	(1)	(1)	(1)	
829	MF 10EO 149	W227466H01	アブラカン	Oil can	(1)	(1)	(1)	(1)	(1)	(1)	(1)	(1)	